

TECHNICAL SPECIFICATION

**Recommendations for renewable energy and hybrid systems for rural
electrification –
Part 2: From requirements to a range of electrification systems**





THIS PUBLICATION IS COPYRIGHT PROTECTED

Copyright © 2015 IEC, Geneva, Switzerland

All rights reserved. Unless otherwise specified, no part of this publication may be reproduced or utilized in any form or by any means, electronic or mechanical, including photocopying and microfilm, without permission in writing from either IEC or IEC's member National Committee in the country of the requester. If you have any questions about IEC copyright or have an enquiry about obtaining additional rights to this publication, please contact the address below or your local IEC member National Committee for further information.

IEC Central Office
3, rue de Varembe
CH-1211 Geneva 20
Switzerland

Tel.: +41 22 919 02 11
Fax: +41 22 919 03 00
info@iec.ch
www.iec.ch

About the IEC

The International Electrotechnical Commission (IEC) is the leading global organization that prepares and publishes International Standards for all electrical, electronic and related technologies.

About IEC publications

The technical content of IEC publications is kept under constant review by the IEC. Please make sure that you have the latest edition, a corrigenda or an amendment might have been published.

IEC Catalogue - webstore.iec.ch/catalogue

The stand-alone application for consulting the entire bibliographical information on IEC International Standards, Technical Specifications, Technical Reports and other documents. Available for PC, Mac OS, Android Tablets and iPad.

IEC publications search - www.iec.ch/searchpub

The advanced search enables to find IEC publications by a variety of criteria (reference number, text, technical committee,...). It also gives information on projects, replaced and withdrawn publications.

IEC Just Published - webstore.iec.ch/justpublished

Stay up to date on all new IEC publications. Just Published details all new publications released. Available online and also once a month by email.

Electropedia - www.electropedia.org

The world's leading online dictionary of electronic and electrical terms containing more than 30 000 terms and definitions in English and French, with equivalent terms in 15 additional languages. Also known as the International Electrotechnical Vocabulary (IEV) online.

IEC Glossary - std.iec.ch/glossary

More than 60 000 electrotechnical terminology entries in English and French extracted from the Terms and Definitions clause of IEC publications issued since 2002. Some entries have been collected from earlier publications of IEC TC 37, 77, 86 and CISPR.

IEC Customer Service Centre - webstore.iec.ch/csc

If you wish to give us your feedback on this publication or need further assistance, please contact the Customer Service Centre: csc@iec.ch.



TECHNICAL SPECIFICATION

**Recommendations for renewable energy and hybrid systems for rural
electrification –
Part 2: From requirements to a range of electrification systems**

INTERNATIONAL
ELECTROTECHNICAL
COMMISSION

ICS 27.160

ISBN 978-2-8322-3064-0

Warning! Make sure that you obtained this publication from an authorized distributor.

CONTENTS

FOREWORD.....	5
INTRODUCTION.....	7
1 Scope.....	8
2 Normative references	8
3 Terms and definitions	8
4 Methodology for non-technical preliminary studies.....	10
4.1 Place and role of preliminary studies in a decentralized rural electrification project	10
4.2 Specifications of the preliminary study	10
4.2.1 General	10
4.2.2 Data for a better understanding of the project environment.....	11
4.2.3 Necessary data for the techno-economic study	12
4.2.4 Necessary data for the financial analysis	14
4.2.5 Necessary data for the organizational study	15
4.3 The stages of a socio-economic study	16
5 Classification of electrification systems.....	16
5.1 Introduction to a range of systems	16
5.2 Users requirements.....	16
5.3 Typology of qualitative requirements	16
5.3.1 Type of desired use	16
5.3.2 Availability	16
5.3.3 Quality of the supply	17
5.4 Typology of quantitative requirements	17
5.5 Classification for electricity services provided	18
5.6 Assisted selection of production subsystem	18
5.7 Typology of decentralized electrification systems	19
5.7.1 General	19
5.7.2 Selection process	19
5.7.3 From user needs to electrification system – Summary for a range of electrification systems	20
6 Electrification systems architecture.....	21
6.1 General.....	21
6.2 General presentation of isolated electrification systems	22
6.2.1 General	22
6.2.2 Production subsystem.....	22
6.2.3 Distribution subsystem.....	22
6.2.4 User or application subsystem or demand subsystem	22
6.3 Combining subsystems	23
6.4 Functional diagrams.....	25
6.5 Related references.....	25
6.6 Limits between production, distribution and demand/application subsystems	26
6.7 Summary of the different electrification system types	26
Annex A (informative) Stages of a socio-economic study	27
A.1 General.....	27
A.2 Preparation phase.....	27

A.3	Drawing up of the questionnaires – choice of surveyors and choice of sample	28
A.4	Conducting the survey – Analysis of the results	28
A.5	Extrapolation of the results	28
Annex B (informative)	Analysis of the type of receivers installed versus types of use and demonstrating seasonable variability (where applicable)	29
B.1	Domestic use	29
B.1.1	General	29
B.1.2	Utilisation – Example 1	30
B.1.3	Utilisation – Example 2	31
B.2	Analysis of the type of receivers versus usage types	32
B.2.1	General	32
B.2.2	Health and care centre	32
B.2.3	Worship places	32
B.2.4	Community centre	32
B.2.5	School	33
B.2.6	Administrative premises	33
B.2.7	Communication system	33
B.2.8	Public lighting	33
B.2.9	Pumping	33
B.2.10	Battery charging station	34
Annex C (informative)	Supply quality indicators for isolated electrification systems	35
Annex D (informative)	Assisted selection of production subsystem	36
D.1	Characteristics of possible production subsystems	36
D.2	Assisted selection of a decentralized production system suited to the requirement	36
Annex E (informative)	Functional diagrams	38
E.1	Glossary of symbols	38
E.2	Architectures of systems	39
E.2.1	Type T ₁ I: REN Systems operating with no storage (in sync with solar, wind or water energy sources) – REN production	39
E.2.2	Type T ₂ I: Individual electrification systems – REN production with energy storage	43
E.2.3	Type T ₃ I: Individual electrification systems: (REN + diesel) production without energy storage	46
E.2.4	Type T ₄ I: Individual electrification systems: (RE + diesel) production with energy storage	49
E.2.5	Type T ₅ I: Individual electrification systems: genset only without storage	51
E.2.6	Type T ₆ I: Individual electrification systems: genset only with storage	52
E.2.7	Type T ₁ C: Collective electrification systems: REN only without storage	53
E.2.8	Type T ₂ C: Collective electrification systems: REN Micropower plant supplying a microgrid	53
E.2.9	Type T ₃ C: Collective electrification systems: Multi sources micropower plant (RE + diesel) without energy storage, supplying a microgrid	56
E.2.10	Type T ₄ C: Collective electrification systems: Multi sources micropower plant (RE + diesel) with energy storage supplying a microgrid	59
E.2.11	Type T ₅ C: Collective electrification systems: Diesel micropower plant supplying a microgrid	62
E.2.12	Type T ₆ C: Collective electrification systems: Diesel micropower plant with energy storage supplying a microgrid	64

Figure 1 – Example of the content of a non-technical preliminary study	11
Figure 2 – Systems architecture and dispatchable energy.....	20
Figure 3 – General configuration of an electrification system	24
Figure A.1 – Flowchart of the stages of a socio economic study.....	27
Figure D.1 – Better adequacy of production subsystems solutions with supply availability and daily duration of service	37
Figure E.1 – Type T ₁ l-a system	40
Figure E.2 – Type T ₁ l-b system	41
Figure E.3 – Type T ₁ l-c system	42
Figure E.4 – Type T ₁ l-d system	43
Figure E.5 – Type T ₂ l system	45
Figure E.6 – Type T ₃ l-a system	47
Figure E.7 – Type T ₃ l-b system	48
Figure E.8 – Type T ₄ l system	50
Figure E.9 – Type T ₅ l system	51
Figure E.10 – Type T ₆ l system	52
Figure E.11 – General architecture of a micropower plant supplying a microgrid	54
Figure E.12 – Type T ₂ C system	55
Figure E.13 – Type T ₃ C-a system	57
Figure E.14 – Type T ₃ C-b system	58
Figure E.15 – Type T ₄ C-a system	60
Figure E.16 – Type T ₄ C-b system	61
Figure E.17 – Type T ₅ C system	63
Figure E.18 – Type T ₆ C system	65
Table 1 – Application types and types of uses.....	16
Table 2 – Expected quality of the supply	17
Table 3 – Synthesis of quantitative requirements/category – Examples of type of user and use.....	18
Table 4 – Typology of decentralized electrification systems	19
Table 5 – Preliminary range of relevant (as a minimum) decentralized electrification systems	21
Table 6 – Recapitulation of characteristics of different types of isolated electrification systems	26
Table C.1 – Combined categorization	35
Table C.2 – Service specification (example)	35
Table D.1 – Principles and characteristics of production subsystems	36
Table E.1 – Glossary of symbols.....	38
Table E.2 – List of cases, type T ₁ l	39
Table E.3 – List of cases, type T ₃ l	46
Table E.4 – List of cases, type T ₃ C	56
Table E.5 – List of cases, type T ₄ C	59

INTERNATIONAL ELECTROTECHNICAL COMMISSION

**RECOMMENDATIONS FOR RENEWABLE ENERGY
AND HYBRID SYSTEMS FOR RURAL ELECTRIFICATION –****Part 2: From requirements to a range of electrification systems**

FOREWORD

- 1) The International Electrotechnical Commission (IEC) is a worldwide organization for standardization comprising all national electrotechnical committees (IEC National Committees). The object of IEC is to promote international co-operation on all questions concerning standardization in the electrical and electronic fields. To this end and in addition to other activities, IEC publishes International Standards, Technical Specifications, Technical Reports, Publicly Available Specifications (PAS) and Guides (hereafter referred to as “IEC Publication(s)”). Their preparation is entrusted to technical committees; any IEC National Committee interested in the subject dealt with may participate in this preparatory work. International, governmental and non-governmental organizations liaising with the IEC also participate in this preparation. IEC collaborates closely with the International Organization for Standardization (ISO) in accordance with conditions determined by agreement between the two organizations.
- 2) The formal decisions or agreements of IEC on technical matters express, as nearly as possible, an international consensus of opinion on the relevant subjects since each technical committee has representation from all interested IEC National Committees.
- 3) IEC Publications have the form of recommendations for international use and are accepted by IEC National Committees in that sense. While all reasonable efforts are made to ensure that the technical content of IEC Publications is accurate, IEC cannot be held responsible for the way in which they are used or for any misinterpretation by any end user.
- 4) In order to promote international uniformity, IEC National Committees undertake to apply IEC Publications transparently to the maximum extent possible in their national and regional publications. Any divergence between any IEC Publication and the corresponding national or regional publication shall be clearly indicated in the latter.
- 5) IEC itself does not provide any attestation of conformity. Independent certification bodies provide conformity assessment services and, in some areas, access to IEC marks of conformity. IEC is not responsible for any services carried out by independent certification bodies.
- 6) All users should ensure that they have the latest edition of this publication.
- 7) No liability shall attach to IEC or its directors, employees, servants or agents including individual experts and members of its technical committees and IEC National Committees for any personal injury, property damage or other damage of any nature whatsoever, whether direct or indirect, or for costs (including legal fees) and expenses arising out of the publication, use of, or reliance upon, this IEC Publication or any other IEC Publications.
- 8) Attention is drawn to the Normative references cited in this publication. Use of the referenced publications is indispensable for the correct application of this publication.
- 9) Attention is drawn to the possibility that some of the elements of this IEC Publication may be the subject of patent rights. IEC shall not be held responsible for identifying any or all such patent rights.

The main task of IEC technical committees is to prepare International Standards. In exceptional circumstances, a technical committee may propose the publication of a technical specification when

- the required support cannot be obtained for the publication of an International Standard, despite repeated efforts, or
- the subject is still under technical development or where, for any other reason, there is the future but no immediate possibility of an agreement on an International Standard.

Technical specifications are subject to review within three years of publication to decide whether they can be transformed into International Standards.

IEC 62257-2, which is a technical specification, has been prepared by IEC technical committee 82: Solar photovoltaic energy systems.

This second edition cancels and replaces the first edition issued in 2004. It constitutes a technical revision.

The main technical changes with regard to the previous edition are as follows:

- redefine the maximum AC voltage from 500 V to 1 000 V, the maximum DC voltage from 750 V to 1 500 V;
- removal of the limitation of 100 kVA system size. Hence the removal of the word “small” in the title and related references in this technical specification.

This technical specification is to be used in conjunction with the other documents of the IEC 62257 series.

The text of this technical specification is based on the following documents:

Enquiry draft	Report on voting
82/947/DTS	82/998A/RVC

Full information on the voting for the approval of this technical specification can be found in the report on voting indicated in the above table.

This publication has been drafted in accordance with the ISO/IEC Directives, Part 2.

A list of all parts in the IEC 62257 series, published under the general title *Recommendations for renewable energy and hybrid systems for rural electrification*, can be found on the IEC website.

Future standards in this series will carry the new general title as cited above. Titles of existing standards in this series will be updated at the time of the next edition.

The committee has decided that the contents of this publication will remain unchanged until the stability date indicated on the IEC website under "<http://webstore.iec.ch>" in the data related to the specific publication. At this date, the publication will be

- transformed into an International standard,
- reconfirmed,
- withdrawn,
- replaced by a revised edition, or
- amended.

A bilingual version of this publication may be issued at a later date.

INTRODUCTION

The IEC 62257 series intends to provide to different players involved in rural electrification projects (such as project implementers, project contractors, project supervisors, installers, etc.) documents for the setting up of renewable energy and hybrid systems with AC voltage below 1 000 V and DC voltage below 1 500 V.

These documents are recommendations:

- a) to choose the right system for the right place;
- b) to design the system;
- c) to operate and maintain the system.

These documents are focused only on rural electrification concentrating on but not specific to developing countries. They should not be considered as all inclusive to rural electrification. The documents try to promote the use of renewable energies in rural electrification; they do not deal with clean mechanisms development at this time (CO₂ emission, carbon credit, etc.). Further developments in this field could be introduced in future steps.

This consistent set of documents is best considered as a whole with different parts corresponding to items for safety, sustainability of systems aiming at the lowest life cycle cost as possible. One of the main objectives is to provide the minimum sufficient requirements, relevant to the field of application that is: renewable energy and hybrid off-grid systems.

The purpose of this part of the IEC 62257 series is to propose a range of renewable energy based electrification systems able to meet the requirements of customers identified in the field of decentralized rural electrification projects.

This technical specification was developed in cooperation with other IEC technical committees and subcommittees dealing with renewable energies and related matters, namely technical committee 21 ("Secondary cells and batteries"), subcommittee 21A ("Secondary cells and batteries containing alkaline or other non-acid electrolytes"), technical committee 64 ("Electrical installations and protection against electric shock"), technical committee 88 ("Wind turbines"), and others.

RECOMMENDATIONS FOR RENEWABLE ENERGY AND HYBRID SYSTEMS FOR RURAL ELECTRIFICATION –

Part 2: From requirements to a range of electrification systems

1 Scope

This part of IEC 62257 proposes a methodological approach for the setting up and carrying out of socio-economic studies as part of the framework of decentralized rural electrification projects. It is addressed to project teams and in particular to experts in charge of socio-economic studies in international projects.

The amount of detail gathered and the requisite number of experts needed would depend on the scale of the proposed project. For large projects involving many households, a detailed study would be required, for a project which involves a single or few households, the study could be truncated.

The information coming from such preliminary studies could be used for several purposes, such as more complete economic and financial studies of the electrification project.

This technical specification also provides some structures as technical solutions that could be recommended, depending on the qualitative and quantitative energy demands, consistent with the needs and financial situation of the customers.

Then, in relation with each model of the proposed range of systems, electrical architectures are proposed to technical project managers to assist in designing the systems.

2 Normative references

The following documents, in whole or in part, are normatively referenced in this document and are indispensable for its application. For dated references, only the edition cited applies. For undated references, the latest edition of the referenced document (including any amendments) applies.

IEC 60617 DB¹, *Graphical symbols for diagrams*

IEC 62257-9 (all parts), *Recommendations for renewable energy and hybrid systems for rural electrification*

IEC 62257-12 (all parts), *Recommendations for renewable energy and hybrid systems for rural electrification*

3 Terms and definitions

For the purposes of this document, the following terms and definitions apply.

¹ “DB” refers to the IEC on-line database, available at <<http://std.iec.ch/iec60617>>

3.1**Renewable Energy****REN**

energy from a source that is not depleted when used

3.2**hybrid system**

multi-sources system with at least two kinds of technologies

3.3**dispatchable power system**

power system is considered dispatchable if delivered power is readily available at any specified time. (e.g. a diesel generator)

3.4**non-dispatchable power system**

power system that is resource dependent and whose power might not be available at a specified time (e.g. solar grid connected system)

3.5**storage**

storage of energy produced by one of the generators of the system and which can be reconverted through the system to electricity

3.6**micropower plant**

power plant that produces less than 50 kVA through the use of a single resource or hybrid system

3.7**microgrid**

grid that transfers a capacity level less than 50 kVA and powered by a micropower plant

3.8**Individual Electrification System****IES**

micropower plant system that supplies electricity to one consumption point usually with a single energy resource point

3.9**Collective Electrification System****CES**

micropower plant and microgrid that supplies electricity to multiple consumption points using a single or multiple energy resource points

3.10**isolated site**

electric characteristic to define a specific location not currently connected to a national/regional grid

3.11**remote site/area**

geographic characteristic to define a specific location far from developed infrastructures, specifically energy distribution

4 Methodology for non-technical preliminary studies

4.1 Place and role of preliminary studies in a decentralized rural electrification project

It is strongly recommended that it is unwise to launch an electrification project against the wishes of the local institutions and populations. A good understanding of the needs and wishes of the local populations is recommended, to know what is their demand, their capacity and willingness to pay for a modern energy service.

If all the socio-economic data are available, they have to be properly collected and processed for this purpose.

If not, a preliminary study is recommended that will be the first stage in the establishment of a feasibility study for a decentralized rural electrification project. Its role is to allow a better understanding of the areas concerned by the various project experts and such a study would make available some of the data needed for technical evaluations, economic, financial and legal analyses, and for the carrying out of the project in general.

In this Clause, a method is suggested to obtain the various information needed.

Some of the information described in the following subclauses might be obtained from governmental organizations prior to specific sites visits.

4.2 Specifications of the preliminary study

4.2.1 General

A socio-economic study shall provide a certain amount of data to the experts in charge of the financial, techno-economic and organizational studies. It also allows a better understanding of the global environment of the project and can provide information to the community about the scope of the project.

The following subclauses suggest some considerations concerning data to be collected and analysed in consideration with the following criteria:

- general information on the environment of the project;
- techno-economic study;
- organizational study;
- financial analysis.

Figure 1 is an illustration of the main topics that should be investigated in the socio-economic study.

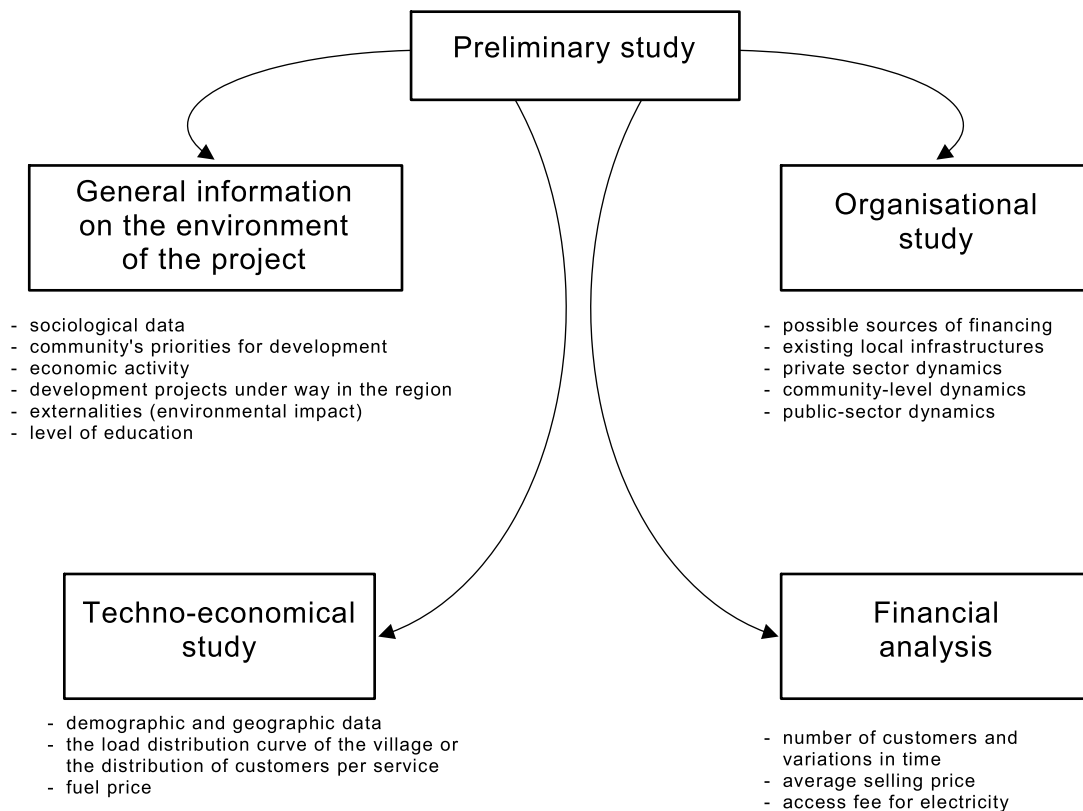

IEC

Figure 1 – Example of the content of a non-technical preliminary study

4.2.2 Data for a better understanding of the project environment

4.2.2.1 General

The following topics should be considered by project contractors. It is their role to determine the relevant importance of each of these categories in regard to a specific project or programme.

4.2.2.2 Sociological data

This data is important for an understanding of the local population. It is essential to look at the organizational, cultural and ethnological structures of the society. In particular, one should investigate the way of life, the sanitary conditions, the national and local languages, the level of education and literacy, the technical sophistication level and the presence of organizations and associations. In addition, the role of male and female in the social organization of the village shall be taken into account.

4.2.2.3 The communities' priorities for development

It is important to understand the population's opinions of their village. What are their priorities for improvement in their daily life? (Such as water pumping, construction of a hospital, of a school, communications infrastructure, electricity, etc.).

In the case of a rural electrification project, what are the priorities for the village as expressed by the population and the local authorities?

4.2.2.4 Economic activities and possible development

Knowledge of the economic activities in the community allows a better general understanding of the environment of the project; it also helps in understanding the dynamics of local development, in order to evaluate the evolution of demand in energy in the coming years.

One can compile the economic activities of the village (commerce, handicrafts, animal husbandry, agriculture, etc.) and look at their relative importance. It would also be useful to look at potential activities due to electricity.

4.2.2.5 The development projects under way in the region

One should look at the local development projects under way, who are the instigators and who are the beneficiaries, what the impacts on the population are, and what would be the impacts on a future electrification project.

4.2.2.6 Environmental considerations

One of the clear drivers in the use of renewable technology is the favourable impact of these systems on the environment as compared to the conventional sources, primarily diesel and grid extension. The impact of any technology choice on the environment, from a carbon, plant footprint, noise and visual impact should be assessed. Understanding the desires of the local participants will be important in this endeavour.

4.2.3 Necessary data for the techno-economic study

4.2.3.1 General

Although this information is not strictly in the domain of the socio-economic expert, it shall be collected in the initial phases of any analysis as it is essential to the techno-economic study. The socio-economic expert is therefore asked to collect this data, being usually the first project person to visit a rural community.

4.2.3.2 Geographic and demographic data

In particular one shall obtain the geographical coordinates of the village, its topography, local fauna, and the geographical distribution of the inhabitants. The geographic layout of the community is important because it impacts the economics of meeting the power requirements for the community. If the community is widely dispersed, the cost of a local distribution network may be prohibitive, at which point individual home systems or small cluster systems may be the most cost-effective solutions. The analysis will require specification of the location, power, and energy requirements of each load. It is also important to obtain an understanding of the acceptance of different qualities of service that these electrification options offer. If possible, one should collect data on the climate, local natural resources, site transportation issues and other important sighting issues such as land ownership and right of way issues.

4.2.3.3 Human resources

The personnel resources available in the community, region and country shall be considered when conducting an analysis for renewable based power systems. The infrastructure required for the project installation, long-term operation, and system maintenance shall be in place to insure its long-term sustainability. In most cases, a multi-layer infrastructure is required, a local system operator who is able to address short-term incidents, a regional service centre capable of conducting system repair and component assessment and a country or globally regional centre that can provide timely replacement of major components and detailed service. Without a specified institutional framework, it will be impossible to provide a quality level of service at a cost that can be sustainable over the life of the project. The whole infrastructure framework relies on people with the right level of training and equipment to perform their specified tasks in the right geographic area with enough systems to guarantee a

successful business model. If the infrastructure is not currently in place, care shall be taken to investigate whether the resources are available to create one.

4.2.3.4 Energy – resources assessments

Data on the local (renewable) energy sources such as wind, insulation, biomass and hydraulic potential should be collected. If a sufficient amount of reliable data is not available, the project should be postponed until the necessary data have been collected. For wind and solar energy, a measurement program may be necessary. For wind measurements, a duration of at least one full year or the ability to comfortably correlate the data to other long-term data collection sites, is recommended.

Information on the daily or seasonal resource pattern is also important in the assessment of the available resource. Modern site assessment techniques should be utilized to establish the best possible prediction of the resource and the energy production potential, including the use of resource assessment modelling techniques such as the Wind Atlas Analysis and Application Program (WASP) Riso National Laboratories, Denmark; MesoMap, True Wind Solutions, United States; and the Wind Resource Assessment and Mapping System (WRAMS), National Renewable Energy Laboratory, United States².

This data can then be used in performance simulation models such as RAPSIM, Australia; RETScreen, Canada; HOMER, Hybrid2, PVSYST, and Wattsun, United States². At locations without electric service, it will also be important to obtain an assessment of all of the electrification options for the community or dwelling in question. This would include information like the distance to any existing distribution network and the cost of diesel fuel transported to the site.

4.2.3.5 Environmental conditions – climate

Data on the local environment and climate should be collected. For warm climates with high temperatures, humidity and possibly corrosive environments may influence design criteria, choice of material and systems layout. For cold climates with low temperatures, icing, snow load and again possible corrosive environment may, in different ways, influence design criteria, choice of material, systems layout and performance. Altitude may also be an important parameter. Local conditions may also influence transport, installation and access to the site as well as operation and maintenance costs. Extreme conditions such as earthquakes, floods and hurricanes/typhoons may influence design criteria and expected systems lifetime. Data on all these matters should be collected and, if possible considered in relation to any national and/or international standard.

4.2.3.6 Existing energy supply

The structure of the existing energy supply in terms of fuel, gas, wood, candles and other sources should be mapped with respect to sources, amounts, availability and costs. Existing infrastructure in terms of power plants, fuel storage and distribution lines should be listed and specified in considerable detail. Costs and metering principles should be accounted for, and subsidies, if any, on the existing energy supply should be accounted for. Special care should be taken in the determination the real cost of diesel fuel delivered to an existing diesel power station. The number of hours of service per day and the customer's impression of the level of service are important factors to consider for any existing power stations.

4.2.3.7 Present and future consumer demands

The expected loads in a community, as well as the projected growth, or reduction, of those loads will impact the specification and configuration of the hybrid system. Determining the initial loads and the growth projections can be very difficult, and is often based on historical

² This information is given for the convenience of users of this document and does not constitute an endorsement by IEC.

values for similar situations. It is very clear that the load and projected growth have a clear relation to system design and the life-cycle cost of energy for systems providing various levels of service. The quality of the electric service, the number of hours per day the system is expected to operate, and whether there are large inductive loads, such as motors, need to be considered. Investigation should also be made into areas of potential power use, for example animal driven agricultural water pumps that could be electrified or grain drying operations that could be converted to biogas.

4.2.4 Necessary data for the financial analysis

4.2.4.1 General

The financial expert needs a number of data to make his analysis, and the socio-economic expert shall provide them. For the financial analysis, one shall know the following:

4.2.4.2 Number of customers and variation in time

This data is deduced from the data on the demand expressed by the population for a modern energy service. In order to evaluate the potential number of customers at the beginning of the project, one shall take into account the social demand (willingness to pay) and the capacity to pay.

To estimate the variations in the number of customers with time, one shall know the demographic growth, and in particular the growth in the number of households (or the average number of persons per household).

4.2.4.3 Availability – willingness to pay

To determine the average selling price for implementing the financial plan, one generally uses the average capacity to pay determined in the previous stage. However it is preferable to determine the willingness to pay of customers for a given service and the distribution of potential customers per service. One then determines the average selling price for each service.

4.2.4.4 Potential sources of financing for the user

It is important to know the various financial institutions and the habits of the local population in their money management. Understanding of their sources of income, and in particular the regularity of their income, allows for better customer management. Questions put to the households lead to knowledge of their preferences and the social acceptability of the different payment methods envisaged.

4.2.4.5 Institutional organizations: potential sources for financing

International and national organizations are potential sources for financing. In relation with the specific goals of the project, it is recommended to have a look to the updated list of these organizations (governmental and NGOs) in order to request their support. Such institutions or organizations can be used to fill the gap between the true project cost and the income coming from the local community. Some projects can be financed only by the local resources, but most of them require assistance from such organizations, commonly the case in developing countries.

4.2.4.6 Connection charge for electricity (initial equipment)

It is important to know if an access fee for electricity can be accepted by the population. If so, what is the adequate fee and what is the willingness to pay of the populations for this access fee?

4.2.5 Necessary data for the organizational study

4.2.5.1 Existing local infrastructures

In order to optimize any decentralized electrification system, one needs to know the transport and communication infrastructures in place. It is necessary to know if they operate all year round (if for example one needs to supply petrol to the village).

One needs to know the distance to the national grid or neighbouring micro-power electrification systems to evaluate the social acceptability of a decentralized system, what are the existing equipment and services available, what electricity supply (if any) the population has access to, and the available communication infrastructures.

4.2.5.2 Private sector dynamics

Private sector dynamics can be evaluated through the number of commerce and handicrafts in the village, as well as the local technical skills: presence of electrical technicians, mechanics, and other activities, etc.

This gives a measure of the capacity of the private sector to support electrification projects in terms of customer management, or even in terms of investment. It is therefore interesting to note the private initiatives under way, such as private micro-grids, battery charging, rental of solar home systems, etc.

4.2.5.3 Community-level dynamics

The capacity for initiative and organization of the local communities should be looked at. This may be evaluated by noting the presence (or absence) of structured local organizations or associations: professional guilds, community infrastructure associations, socio-cultural associations, etc. It is also essential to note the presence of community-level electrification projects, such as micro-grids.

Generally, the fewer of these organizations are present, the lower will be the organizational capacity of the community. In this case, it is difficult to imagine a management of the electrification project purely on a community level.

4.2.5.4 Public sector dynamics

This dynamic can be evaluated by looking at the public sector (state, local authorities) projects under way in the village. If they are few, one can conclude that generally speaking, a public sector management approach for electrification projects is not appropriate.

4.2.5.5 Local governmental issues

There will be a number of local and federal governmental issues that will have to be assessed prior to project implementation. Items include financing and subsidy issues, responsibility for system operational status, import tariffs, land use issues and power production legislation and regulation. In many cases, governmental barriers to the use of new and renewable rural electrification technology are the hardest to overcome and result in the most project delays.

4.2.5.6 Institutional organizations

International and national organizations are potential sources for organization support. In relation with the specific goals of the project, it is possible to find organizations with specific experience, for example business development.

4.3 The stages of a socio-economic study

The main steps recommended to be followed for the carrying out of a socio economic study are presented at the end of the present document as Annex A.

5 Classification of electrification systems

5.1 Introduction to a range of systems

This clause establishes a classification system of decentralized electrification systems for rural areas not connected to a national/regional grid, based on a range of system types.

5.2 Users requirements

From the users' point of view, the following two kinds of requirements should be considered:

- a) Quality requirements, including:
 - time availability: the ability to use power whenever needed,
 - waveform quality of the supply neither impairing the operation nor the life duration of receivers.
- b) Quantity requirements, whose characteristics are:
 - quantity of energy required for a given period, allowing to take advantage of the number of utilization hours expected from installed receivers.

5.3 Typology of qualitative requirements

5.3.1 Type of desired use

Energy use/application types are listed in Table 1. The categories shown are issued from an analysis of user types (individual or collective) and from the use they desire to (or can) make of their power/energy:

Table 1 – Application types and types of uses

Application types	Types of uses
Home applications	Lighting Audio/video Refrigerator(s) Small household appliances Washing machine Irons Freezer(s) Odd jobs
Public areas applications (Places of collective life: worship places, community centre, health centre, etc.)	The same appliances as above are used, but commonly more numerous and more powerful Public lighting Collective pumping
Economic activities applications	Process equipment supply (mainly motors)

5.3.2 Availability

Considering the daily duration of the desired/required service availability, each type of use can be identified in relation to increasing requirements in terms of:

- Duration of service (hours per day).
- Service availability (% per year).
- Power quality.

5.3.3 Quality of the supply

Concerning the quality of the supply, the expectations of the users will bear upon parameters which allow satisfactory usage of appliances. Table 2 lists examples of qualitative expectations versus categories of receivers.

Table 2 – Expected quality of the supply

Type of receivers	Qualitative expectations
DC	Voltage measured at receivers level ($U \pm \Delta U$) Signal distortion
AC	Voltage measured from the point of delivery ($U \pm \Delta U$) Frequency ($f \pm \Delta f$) Harmonic distortion (THD) Grid $\cos \varphi$

The specific values are given in Table C.1.

5.4 Typology of quantitative requirements

Annex B provides a detailed analysis of power quantitative requirements linked to the types of commonly used receivers installed in each aforementioned application; it also provides an estimate of the time during which these receivers may be used.

Using this detailed analysis, power and energy requirements were broken down into four categories as shown in Table 3 below.

**Table 3 – Synthesis of quantitative requirements/category –
Examples of type of user and use**

Examples of Quantitative Requirements <i>please add a heading</i>	Category 1	Category 2	Category 3	Category 4
User type (examples of type of use)	Individual services (lighting and audio/video) and collective services "low energy consumption" (places of worship, community centre, administrative premises, communication systems, etc.)	Individual services (same as category 1 + freezer(s) and household appliances) and collective services (health and care centre: lighting and freezer(s), etc.)	Individual services (same as category 2 + freezer(s), washing machine, odd jobs, etc.) and collective services (public lighting)	Collective services (pumping, etc.) and business activities (motors, etc.)
Essential consumption characteristics	<ul style="list-style-type: none"> • Low number of receivers • Low power of receivers • Slim consumption profile 	<ul style="list-style-type: none"> • Number of receivers is a little higher • Receivers more powerful 	<ul style="list-style-type: none"> • High number of receivers • Some receivers are powerful • High instantaneous power inrush calls (possibly) • "Variable" consumption profile 	<ul style="list-style-type: none"> • Powerful receivers • High instantaneous power inrush calls
Probable needed power	$P \leq 100 \text{ W}$	$0,1 \text{ kW} < P < 0,5 \text{ kW}$	$0,5 \text{ kW} \leq P < 2 \text{ kW}$	$2 \text{ kW} \leq P$
Average energy required over 24 h (to satisfy the users as may be expected from using electricity)	$E \leq 0,5 \text{ kWh}$	$E \leq 1,5 \text{ kWh}$	$E < 4 \text{ kWh}$	$E < n \times 10 \text{ kWh}$

Most domestic users in developing countries apply to category 1 and to a lesser extent, to category 2.

5.5 Classification for electricity services provided

Several levels of service can exist to meet the quantitative requirements shown in Table 3; these levels of service can be distinguished from one another through the indicators.

As a suggestion, Annex C indicates values to specify supply quality for rural electrification systems (Table C.1).

5.6 Assisted selection of production subsystem

Annex D, an informative Annex, suggests how to determine the most adequate power production subsystem solution with supply availability and daily duration of service.

5.7 Typology of decentralized electrification systems

5.7.1 General

The following classification is provided in order to better communicate the different types of commonly used isolated electrification systems.

5.7.2 Selection process

A production subsystem is selected as a function of qualitative requirements for power availability and offer related constraints. Production and distribution shall then be sized in order to fulfil quantitative requirements.

Table 4 categorizes the production subsystems (generators) in terms of the possible system architectures:

Table 4 – Typology of decentralized electrification systems

Type of generator		Classification of associated systems	
		Individual	Collective
RE only, hybrid or not	no storage	T ₁ I	T ₁ C
RE only, hybrid or not	storage	T ₂ I	T ₂ C
RE, hybrid or not + Genset	no storage	T ₃ I	T ₃ C
RE, hybrid or not + Genset	storage	T ₄ I	T ₄ C
Genset only	no storage	T ₅ I	T ₅ C
Genset only	storage	T ₆ I	T ₆ C
Notation principle: T _i I : individual system, type <i>i</i> ; T _j C : collective system, type <i>j</i> . NOTE "Storage" : storage of energy produced by one of the generators of the system and which can be reconverted "on demand" to electricity through the system.			

Figure 2 below categorizes systems depending on whether they are dispatchable or not.

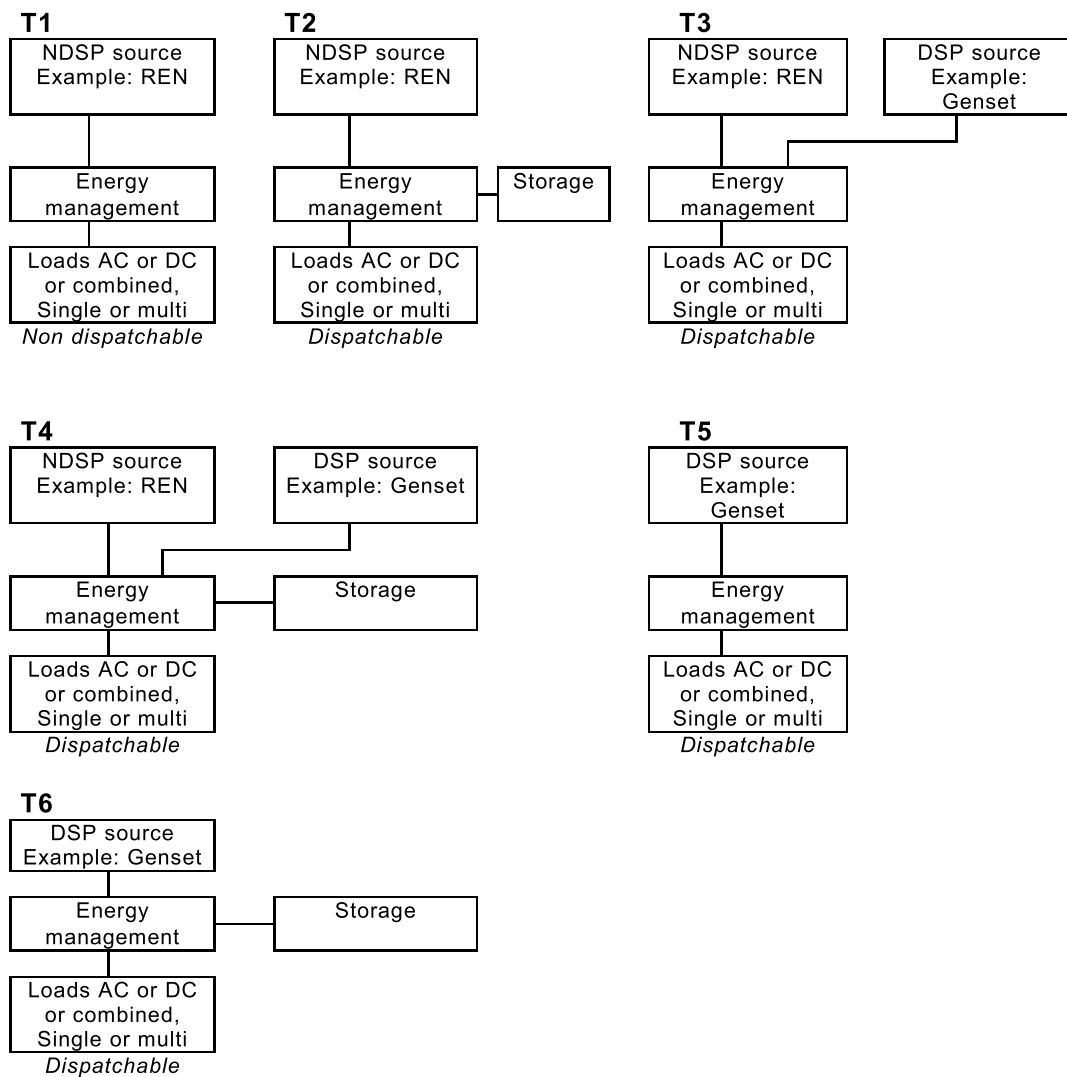

IEC

Figure 2 – Systems architecture and dispatchable energy

5.7.3 From user needs to electrification system – Summary for a range of electrification systems

Table 5 specifies the range of electrification systems including their architectures and the demand requirements:

- type of recommended production subsystem;
- type of sources constituting the production subsystem;
- type of rural decentralized electrification systems integrating the said production subsystems;
- contractual commitments between suppliers, operators and users.

Table 5 – Preliminary range of relevant (as a minimum) decentralized electrification systems

Requirement	Proposed production subsystem			Electrification system		Proposals for contractual commitments between suppliers, operators and users (when applicable)
	REN	Storage	Genset	IES	CES	
User requests a given result of process over a given period; no quality requirement	X			T ₁ I	N/A	Commitment to supply: – process result defined for a period of one month, one week, for a number of <i>n</i> months out of 12, <i>n</i> weeks out of 52 or <i>n</i> days out of 365
Every day, user would like to have multiple hour energy supply at constant voltages with several appliances on, simultaneously and accepts a lack of energy because of adverse climatic conditions	X	X		T ₂ I	T ₂ C	Commitment to supply: – the quantity of subscribed power/energy defined for a period of one month, one week, for a number of <i>n</i> months out of 12, <i>n</i> weeks out of 52 or <i>n</i> days out of 365
Every day, user would like to have multiple hour energy supply at constant voltages with several appliances on, simultaneously and requires energy even in adverse climatic conditions and accepts to have energy only during defined periods in the day	X		X	T ₃ I	T ₃ C	Commitment to supply: – the quantity of subscribed power/energy defined for a period of one month, one week, for a number of <i>n</i> months out of 12, <i>n</i> weeks out of 52 or <i>n</i> days out of 365 – adequate fuel source(s) and sufficient fuel storage capabilities to support genset operations NOTE Renewable based systems will require less fuel than non-renewable. – service availability over fixed time periods
			X	T ₅ I	T ₅ C	
	X	X	X	T ₄ I	T ₄ C	
or would like to have energy 24 h/day				T ₆ I	T ₆ C	Same as above, but 24 h service availability
NOTE In this presentation, possible system failures do not account as days of unavailability. Unavailability is here considered either linked: – to system maintenance, or – to generator (if one exists) overhaul, or – to climatic trouble (number of consecutive days with no sun or wind).						

6 Electrification systems architecture

6.1 General

This Clause presents the architecture of the six system types defined in the typology in Table 4.

6.2 General presentation of isolated electrification systems

6.2.1 General

In general isolated electrification system can be broken down into three parts:

- a) energy production subsystem;
- b) energy distribution subsystem;
- c) energy application subsystem.

6.2.2 Production subsystem

The production system comprises equipment for:

- generating electricity, supplied by:
 - renewable energies such as the sun or wind, hydro, biomass (photovoltaic panels, wind-turbines);
 - fossil energy (gas-oil, motor spirit, kerosene) used as fuel for a generator set.
- storage of electric energy.
- conversion/transformation of energy by converters:
 - DC / DC convertors;
 - AC / DC (rectifiers);
 - DC / AC (inverters).
- protection of persons and goods by:
 - circuit-breakers;
 - fuses;
 - neutral and earthing control devices.
- management of energy by:
 - basic regulators without energy management systems;
 - energy management systems (may include monitoring capability and remote access).

Certain parts of this equipment may be placed in boxes, cabinets or other edifices also comprising functions such as ventilation or alarm systems.

6.2.3 Distribution subsystem

The distribution subsystem comprises the equipment for distributing the energy in the form of alternating or direct current from the production subsystem to the demand subsystem. It comprises:

- **distribution** equipment:
 - switchboards, cabinets, etc.
- **energy transmission** equipment:
 - cables (overhead or underground);
 - poles;
 - protection.
- **instrumentation** equipment.

NOTE This subsystem is defined only for collective electrification systems.

6.2.4 User or application subsystem or demand subsystem

This subsystem consists of all the equipment using the energy:

- the user power supply box (including metering and safety equipment);
- the internal wiring installation;
- the demand appliances including:
 - receivers operating on DC;
 - receivers operating on AC.

6.3 Combining subsystems

In the most basic form, a rural micropower plant can be made up of multiple energy production, distribution and application subsystems as shown in Figure 3. The distribution subsystems make up the common connection between distinct production subsystems and distinct applications subsystems. In most cases, the distribution subsystems will be specified for AC supply quality.

Because of the requirement that multiple AC supplying production subsystems shall be able to maintain consistent AC quality of supply, the most simple form of rural micropower plant will contain one production subsystem, one distribution subsystem and one application subsystem itself made up of multiple users. However, multiple production, distribution and application subsystems are encompassed by this document.

The specific functional diagrams addressed in the Annexes A to E address a single production subsystem while the complexities of combinations of multiple production, distribution and application subsystems is addressed in IEC TS 62257-12.

For a glossary of symbols, see Table E.1.

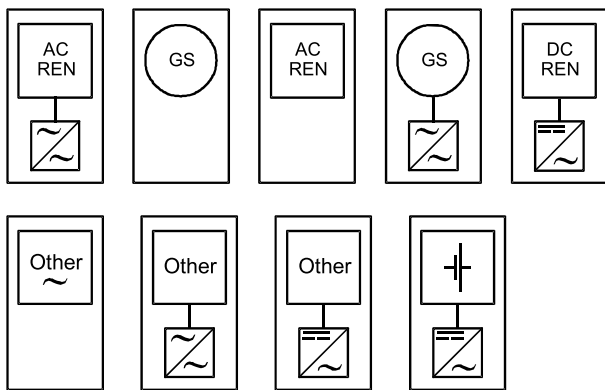
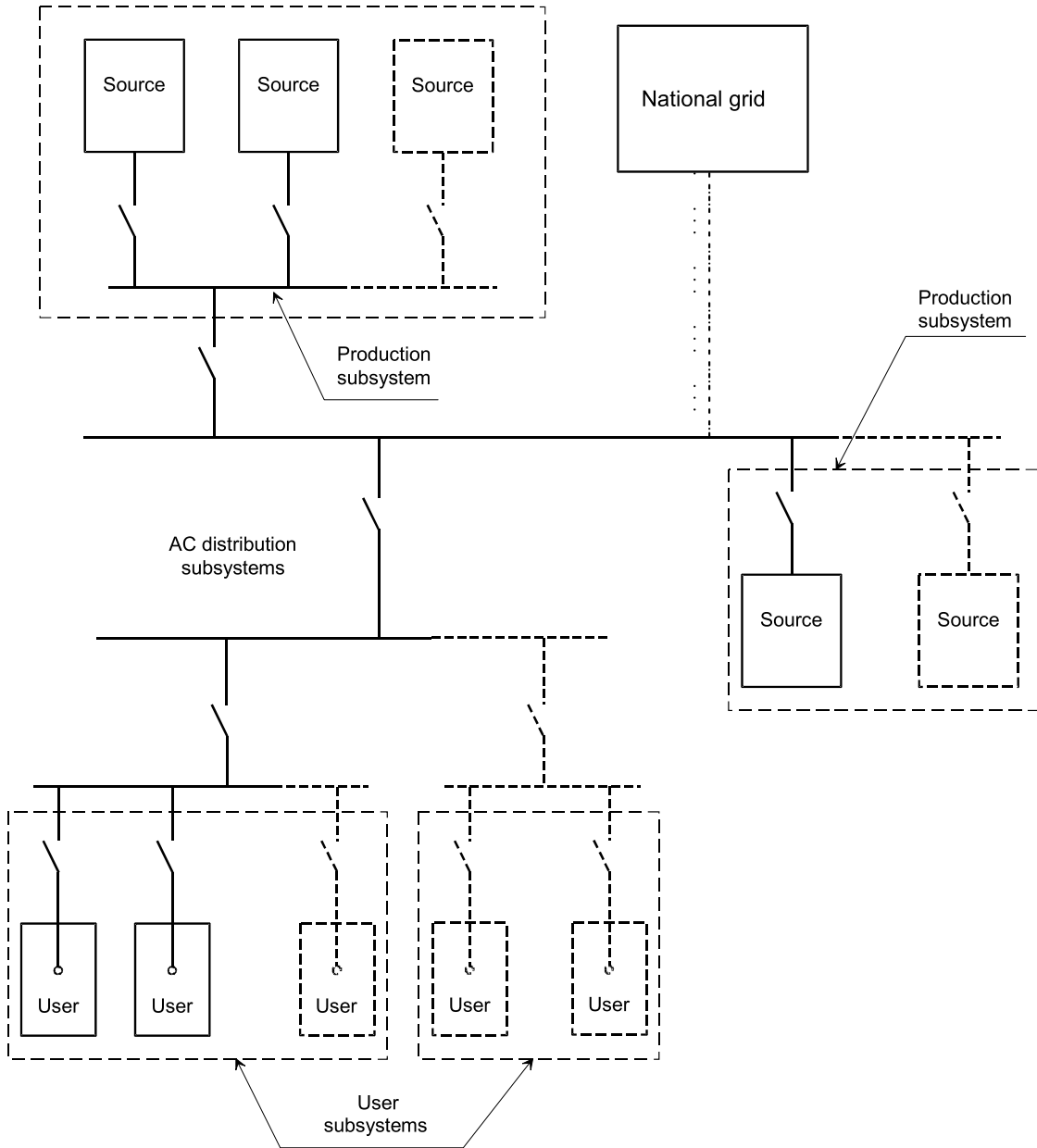

Source examples

Figure 3 – General configuration of an electrification system

6.4 Functional diagrams

Annex E, an informative Annex, introduces suggested diagrams that could be considered as a first step to implement electrification systems as simply as possible, referring to the general configuration as illustrated in 6.3.

The diagrams shown in Figures E.1 to E.18 are functional diagrams and not electrical diagrams.

They are highly general in nature and capable of adapting to a wide variety of situations. In particular, they do not suggest ownership.

The intention is to provide these functional diagrams as examples of systems capable of being used throughout the world, both in developed and developing countries. The systems can be further sub categorised using the quantity and quality of supply performance indicators as given in Annex C. The quantity and quality of supply determines the dimensions of the different parts of the system: generators, storage, cut-off points, types of protection, etc.

The switch points indicated on the diagrams are common-purpose, with no indication as to the specific type of switchgear to be used.

The limits between the subsystem types (production, distribution, demand/application) are drawn.

Individual Electrification Systems (IES) for single users incorporate two subsystems:

- an electrical power production subsystem;
- a demand subsystem for utilizing this electrical power.

Collective Electrification Systems (CES) for multiple users incorporate three subsystems:

- an electrical power production subsystem (micropower plant);
- a distribution grid for sharing/ this power to individual users (microgrid);
- a demand subsystem including in-home wiring and user's electrical appliances for all individual users.

These subsystems may correspond to systems operated and maintained by different persons or bodies. In certain cases, the entire system may be owned, operated and used by the same person.

Persons or bodies who may have the task of operating such systems can choose best suited type of supply system.

Typically, such supply options may be:

- delivery of DC power;
- delivery of AC power, with the inverter forming part of the production subsystem;
- delivery of power in two forms (AC and DC);
- a single delivery point (AC or DC);
- several delivery points.

6.5 Related references

In IEC TS 62257-9 there is a proposal for a standard about house wiring for locations with no existing standards.

6.6 Limits between production, distribution and demand/application subsystems

Where there are several different operators, they may choose to set the supply modes for their respective areas of action that they consider the best suited to them, taking into consideration the priorities they themselves set, namely:

- a single delivery point;
- several delivery points;
- delivery in DC form;
- delivery in AC form;
- a back-up set forming part of the application subsystem;
- etc.

NOTE Delivery at a standard voltage yet to be defined (DC voltage of 24 V, AC voltage of 230 V, for instance) implies, in certain cases, that certain converters be taken over by the production system operator.

In designing the systems, it should be possible when working on installations, to apply the safety rules stipulated by the standards applicable in the countries concerned or, failing this, rules set by the owner or local operator.

6.7 Summary of the different electrification system types

Table 6 summarizes the main functional characteristics of the different types of isolated electrification systems.

Table 6 – Recapitulation of characteristics of different types of isolated electrification systems

Electrification system	System type	Production system			Conversion	Coupling	Application		
		REN	Storage	Generator set			REN/group synchronous coupling	DC	AC
REN in-sync process supply systems and Individual systems (IES)	T ₁ I-a	*					*		
	T ₁ I-b	*						*	
	T ₁ I-c	*			*			*	
	T ₁ I-d	*			*		*		
	T ₂ I	*	*		*		*	*	
	T ₃ I	*		*				*	
	T ₄ I	*	*	*	*		*	*	*
Collective systems (CES)	T ₁ C	Considered as non-relevant							
	T ₂ C	*	*		*			*	
	T ₃ C-a	*	*	*	*	*		*	
	T ₃ C-b	*	*	*	*	*		*	
	T ₄ C	*	*	*	*			*	*
	T ₅ C			*				*	
	T ₆ C		*	*	*			*	

*: Equipment present.

Annex A (informative)

Stages of a socio-economic study

A.1 General

This annex briefly presents the principal steps to be followed when carrying out a socio-economic survey or study in decentralized rural electrification. Depending on the type of project considered, the stages to be followed may vary slightly or be optional. See also Clause 4.

Figure A.1 is an example of what could be done.

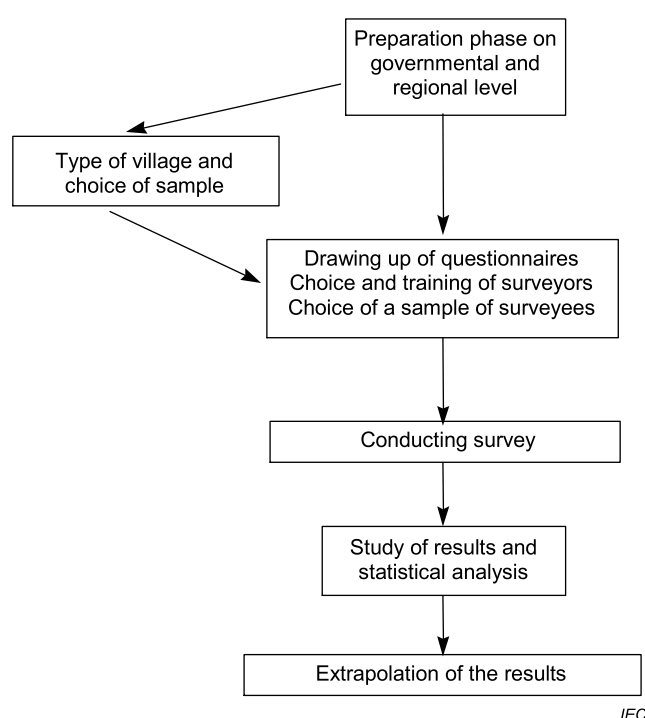

Figure A.1 – Flowchart of the stages of a socio economic study

A.2 Preparation phase

When a rural electrification project is to be set up, a preliminary analysis of the general characteristics of the zone should be made before launching exploratory trips. This analysis should look at the factors that characterise the zone such as the geographical situation and the political system, the national energy situation and the different sources of energy, and the economic situation.

To supplement this data and to understand the local context optimally, it is recommended to make a first exploratory trip.

A.3 Drawing up of the questionnaires – choice of surveyors and choice of sample

Surveys allow the collection of data necessary for the setting up of a decentralized rural electrification project. The quality of the surveyors determines to a large extent the reliability and exactitude of the data collected. It is therefore preferable to make use of surveyors who are used to participating in field surveys in rural areas. In addition, in some countries several languages or dialects are used and it is necessary to have surveyors fluent in the language(s) used in the villages concerned.

The reliability of the extrapolation of the results to the whole of the village or villages strongly depends on the quality of the sample and its representation. This supposes that the size of the sample be sufficient, and that the sample includes the various geographical and socio-economic situations encountered in the zone concerned.

A.4 Conducting the survey – Analysis of the results

The questionnaires should be created by professional operators, often recruited in local or national statistical organizations. To avoid errors, a backup can be made. Treatment of the data should allow elimination of inconsistent answers.

A.5 Extrapolation of the results

Since only a sample of the population is surveyed, the results should then be extrapolated to the whole of the village.

The corrected data is then treated to determine the statistical data necessary for the rest of the project; input for the technical, financial and organizational studies are available. The survey results give, for each survey, current expenditures in energy (assimilated to the capacity to pay), the choice of an energy service and the willingness to pay. This data allows an evaluation of the solvable demand for each survey.

Annex B (informative)

Analysis of the type of receivers installed versus types of use and demonstrating seasonable variability (where applicable)

B.1 Domestic use

B.1.1 General

See also Clause 5.

NOTE The following data is listed for guidance and concerns villages located in developing countries.

B.1.2 Utilisation – Example 1

							Category I (lighting and audio/video)			Category II (category I + freezer(s) + household appliances)				Category III (category II + washing machine, odd jobs)				
							90	280	400	590	880	970	1 030	1 120	1 680	2 730	2 830	3 180
	Equipment	Unit power (W)	Qty.	Operating duration (h/day)	Installed appliances (W)	Daily energy (Wh/day)												
Lighting	Lamps	10	3	3	30	90	1		1		1		1		1			
		10	6	3	60	180		1		1		1		1		1	1	1
Audio/video	Radio	20	1	5	20	100		1	1	1	1	1	1	1	1	1	1	1
	TV	70	1	3	70	210			1	1	1	1	1	1	1	1	1	1
	Video	50	1	2	50	100				1			1	1			1	1
Cold	Refrigerator	80	1	6	80	480					1	1	1	1	1	1	1	1
	Freezer	160	1	6	160	960										1	1	1
Comfort	Household appliances	100	1	0,5	100	50							1	1	1	1	1	1
	Washing machine	500	1	1,5	500	750									1	1	1	1
	Odd jobs	700	1	0,5	700	350												1
Total installed power P_{inst} (W)							30	80	120	200	200	230	350	380	800	990	1 040	1 740

B.1.3 Utilisation – Example 2

							Category I (lighting and audio/video)			Category II (category I + freezer(s) + household appliances)				Category III (category II + washing machine, odd jobs)				
							180	560	730	1 010	1 210	1 390	1 360	1 540	2 010	3 150	3 250	3 600
Total daily energy (Wh/day)																		
	Equipment	Unit power (W)	Qty.	Operating duration (h/day)	Installed appliances (W)	Daily energy (Wh/day)												
Lighting	Lamps	10	3	6	30	180	1		1		1		1					
		10	6	6	60	360		1		1		1		1		1	1	1
Audio/video	Radio	20	1	10	20	200		1	1	1	1	1	1	1	1	1	1	1
	TV	70	1	5	70	350			1	1	1	1	1	1	1	1	1	1
	Video	50	1	2	50	100				1		1	1				1	1
Cold	Refrigerator	80	1	6	80	480				1	1	1	1	1	1	1	1	1
	Freezer	160	1	6	160	960									1	1	1	1
Comfort	Household appliances	100	1	0,5	100	50						1	1	1	1	1	1	1
	Washing machine	500	1	1,5	500	750								1	1	1	1	1
	Odd jobs	700	1	0,5	700	350												1
Total installed power P_{inst} (W)							30	80	120	200	200	230	350	380	800	990	1 040	1 740

NOTE These tables are only examples and of course it is possible to use any relevant appliances, or combination of appliances, matching the available power.

B.2 Analysis of the type of receivers versus usage types

B.2.1 General

Collective use

NOTE This data is shown for guidance and concerns villages of developing countries.

B.2.2 Health and care centre

Equipment	Unit power (W)	Quantity	Operating duration (h/d)	Installed appliances (W)	Related daily energy (Wh/d)
Lamps	10	3	6	30	180
Refrigerator	80	1	6	80	480
Sterilizer	400	1	0,5	400	200
				Energy/day (Wh/day)	10 200
				P_{inst} (W)	510

Sizing should account for the powers called for on starting up generator motors (if such motors exist).

B.2.3 Worship places

Equipment	Unit power (W)	Quantity	Operating duration (h/d)	Installed appliances (W)	Related daily energy (Wh/d)
Lamps	10	3	2	30	60
Microphone + P.A. amplifier	50	1	1	50	50
				Energy/day (Wh/day)	110
				P_{inst} (W)	80

B.2.4 Community centre

Equipment	Unit power (W)	Quantity	Operating duration (h/d)	Installed appliances (W)	Related daily energy (Wh/d)
Lamps	10	4	6	40	240
TV	70	1	5	70	350
Radio	20	1	5	20	100
				Energy/day (Wh/day)	690
				P_{inst} (W)	130

B.2.5 School

Equipment	Unit power (W)	Quantity	Operating duration (h/d)	Installed appliances (W)	Related daily energy (Wh/d)
Lamps	10	6	6	60	360
				Energy/day (Wh/day)	360
				P_{inst} (W)	60

B.2.6 Administrative premises

Equipment	Unit power (W)	Quantity	Operating duration (h/d)	Installed appliances (W)	Related daily energy (Wh/d)
Lamps	10	2	6	20	120
				Energy/day (Wh/day)	120
				P_{inst} (W)	20

B.2.7 Communication system

Equipment	Unit power (W)	Quantity	Operating duration (h/d)	Installed appliances (W)	Related daily energy (Wh/d)
System	100	1	2	100	200
				Energy/day (Wh/day)	200
				P_{inst} (W)	100

B.2.8 Public lighting

Equipment	Unit power (W)	Quantity	Operating duration (h/d)	Installed appliances (W)	Related daily energy (Wh/d)
Lamps	18	30	6	540	3 240
				Energy/day (Wh/day)	3 240
				P_{inst} (W)	540

B.2.9 Pumping

Equipment	Unit power (W)	Quantity	Operating duration (h/d)	Installed appliances (W)	Related daily energy (Wh/d)
Pump	1500	4	12	6 000	72 000
				Energy/day (Wh/day)	72 000
				P_{inst} (W)	6 000

B.2.10 Battery charging station

Equipment	Unit power (W)	Quantity	Operating duration (h/d)	Installed appliances (W)	Related daily energy (Wh/d)
Charger	500	1	10	500	5 000
				Energy/day (Wh/day)	5 000
				P_{inst} (W)	500

Annex C (informative)

Supply quality indicators for isolated electrification systems

Table C.1 gives specific values of the supply quality. See also Clause 5.

Table C.1 – Combined categorization

Requirement class	Power quality indicators						
	Specified duration of service ^{a)} (h/day)	Specified supply availability (%/year)			Required power quality		
		1	2	3	1	2	3
A	= 24 h	≥ 99	≥ 98	≥ 95	±ΔU ≤ 10 % U _N ±Δf ≤ 1 Hz THD ≤ 3 %	±ΔU ≤ 15 % U _N ±Δf ≤ 2 Hz THD ≤ 5 %	±ΔU ≤ 20 % U _N ±Δf ≤ 3 Hz THD ≤ 10 %
B	16 ≤ h < 24						
C	8 ≤ h < 16						
D	4 ≤ h < 8						
E	h < 4						
F	Systems requiring power quality indicators either above or below these values may be specified according to special requirements.						
<p>U_N: the r.m.s. voltage at a given time at the supply terminals, measured over a given interval.</p> <p>f: the nominal frequency of the supply voltage U_N should be f. Under normal operating conditions the mean value of the fundamental frequency measured over 10 s should be within the range of $f \pm \Delta f$.</p> <p>a) Start time and end time of the period for the duration of service should be implemented in the contract.</p>							

Finally, the service provided will be a combination of quantitative and qualitative requirements to fulfil the user's power and energy needs:

In reference to Table 3 and Table C.1, RE systems will be specified as follows:

Service X = (power-energy category combined with qualitative class)

As an example, Table C.2 illustrates the content of a specification of a Cat 1-D13 service:

Table C.2 – Service specification (example)

Cat 1		D	1	3
Maximum available power demand:	$P \leq 100 \text{ W}$	Weekly average service providing energy 4 h per day, as a maximum.	Service provided for more than 99 % of the year	±ΔU ≤ 20 % U _N , ±Δf ≤ 3 Hz, THD ≤ 10 %
Average energy provided over 24 h	$E \leq 0,5 \text{ kWh}$			

Annex D (informative)

Assisted selection of production subsystem

D.1 Characteristics of possible production subsystems

The various production subsystems envisioned for Decentralized Rural Electrification (DRE), are shown in Table D.1 below. See also Clause 5.

Table D.1 – Principles and characteristics of production subsystems

Principle	Remarks	Production characteristics
Production without storage	The production issued from renewable energies alone is erratic and depends on climatic conditions. The availability from a genset alone can be operated in accordance with the demand.	Time dependent On demand
Production with short term energy storage	In this case, the storage associated with REs is limited to a low capacity buffer storage. This short-term energy storage is used both for setting voltages to users requirements and compensating for production trouble as may occur during the generator start-up period. The storage is not designed for the storage of RE produced energy.	Rigid
Production with long term energy storage	In this production mode, storage is combined with RE, hence providing flexibility compared to the previous solutions. Because of climatic problems, it may occur that this type of system will be unavailable several days per year. In this configuration, supply problems can occur several days per year.	Flexible
	With a generator set, any possible unavailability due to climatic problems is removed. Here supply is secured.	

D.2 Assisted selection of a decentralized production system suited to the requirement

If the user is satisfied with a supply of energy per week or per month and there is no user's demand regarding the quality of the supply, a production of Renewable Energies as-they-go (REs alone) will be suitable.

In case the user desires a daily supply and likewise, accepts that his/her system will be unavailable several days per year because of climatic hazards, a solution combining a storage and REs will be suitable.

If the user desires a daily supply and likewise, wants to be fully protected against climatic hazards (meaning a generator set is provided or oversized RE and storage exist), several solutions may be suitable:

- One generator set alone (in case of multiple user systems) or a multi sources solution (generator set + REs) with synchronous coupling and buffer storage (generator set associated with a pseudo-as-it-goes production of REs). In this case, provisions should be made to make sure the user accepts to be supplied according to predetermined time zones.
- A production with storage either including a generator alone or, a multi-source production (generator set + REs) or, REs in which case both REs and storage should be oversized. These solutions will provide the user with flexibility for utilizing his/her system. The allocated energy can be consumed by the user at his/her own discretion over a cycle of 24 h.

Figure D.1 summarizes the selection process of the appropriate production sources that are recommended as relevant with the user's requirements.

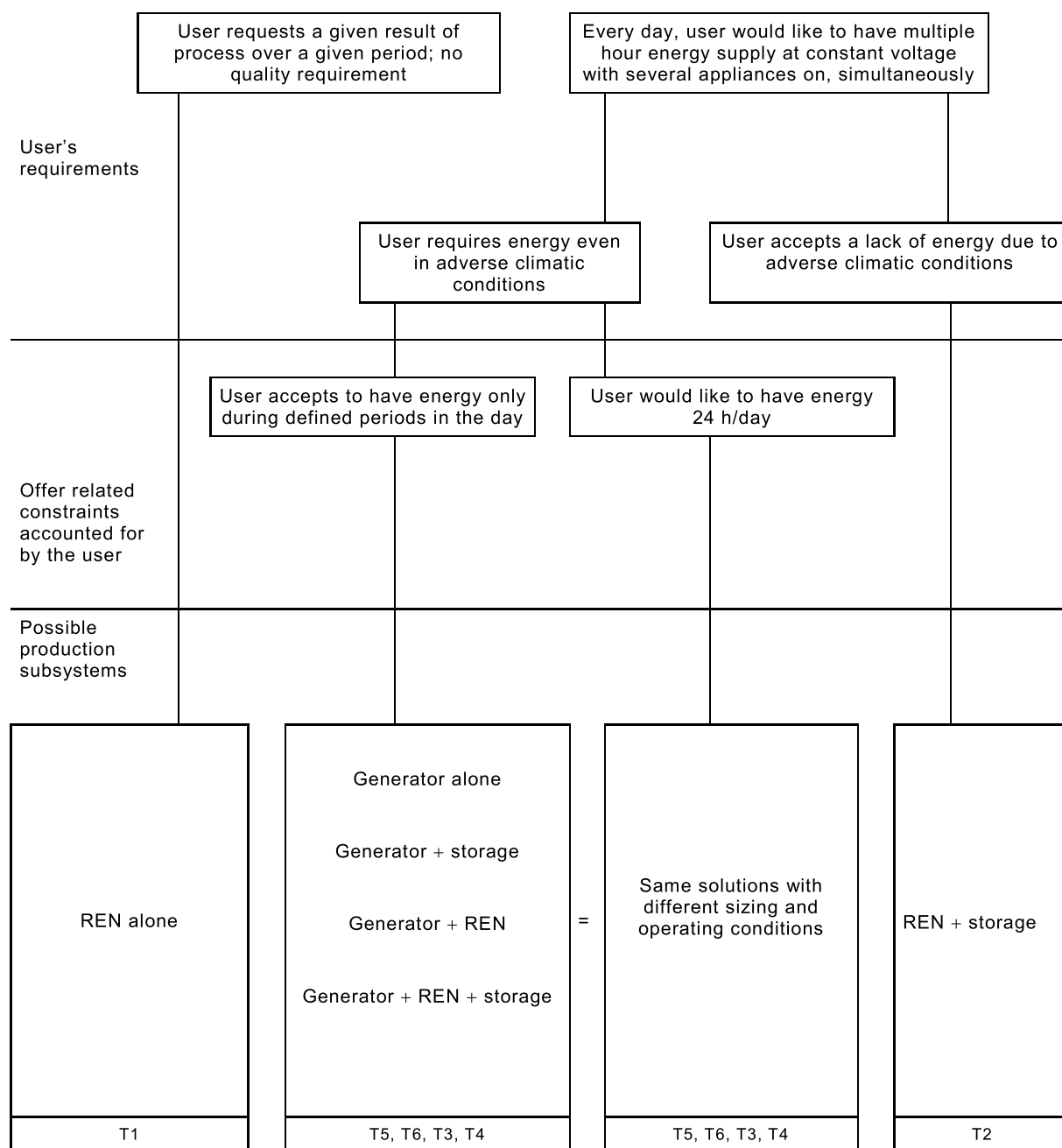

IEC

Figure D.1 – Better adequacy of production subsystems solutions with supply availability and daily duration of service













Annex E (informative)

Functional diagrams

E.1 Glossary of symbols

See also Clause 6.

Table E.1 – Glossary of symbols

Symbol	IEC 60617 Reference	Description	Specific note
	IEC 60617-2-S00059 (DB:2001-7) ^{a)}	Object (equipment, functional unit, component)	Suitable legends should be inserted in or added to the symbol outline to indicate the type of object For example: <div style="display: flex; flex-direction: column; align-items: center;"> <div style="border: 1px solid black; padding: 2px; margin-bottom: 5px;">DC REN</div> <div style="margin-bottom: 5px;">DC generator using renewable energy</div> <div style="border: 1px solid black; padding: 2px; margin-bottom: 5px;">AC REN</div> <div>AC generator using renewable energy</div> </div>
	IEC 60617-6-S00819 (DB:2001-7) ^{a)}	Synchronous generator	Alternatively genset (synchronous generator of the genset)
	IEC 60617-6-S00894 (DB:2001-7) ^{a)}	Rectifier	
	IEC 60617-6-S00896 (DB:2001-7) ^{a)}	Inverter	
	IEC 60617-3-S00017 (DB:2001-7) ^{a)}	Terminal	
	IEC 60617-2-S00154 (DB:2001-7) ^{a)}	Mechanical interlock between two devices	
	IEC 60617-6-S01342 (DB:2001-7) ^{a)}	Battery of secondary cells	
	IEC 60617-S01410 (DB: 2001-11) ^{a)}	Frame, chassis	
	IEC 60617-2-S00200 (DB:2001-7) ^{a)}	Ground (earth), general symbol	
	IEC 60617-7-S00227 (DB:2001-7) ^{a)}	General symbol for a switch, make contact	
	IEC 60617-7-S00229 (DB:2001-7) ^{a)}	Break contact	
	IEC 60617-7-S00373 (DB:2001-7) ^{a)}	Lightning arrester	

^{a)} "DB" refers to the IEC on-line database, available at <http://std.iec.ch/iec60617>.

E.2 Architectures of systems

E.2.1 Type T₁I: REN Systems operating with no storage (in sync with solar, wind or water energy sources)³ – REN production

This type of system is primarily intended for supplying processes in situations where it is not desired or possible to store the electrical energy. Examples of application: pumping of water, ventilation of premises, etc.

Several cases can be envisaged, depending on the type of production source (photovoltaic or wind-turbine) and the type of application equipment to be supplied (AC or DC). The cases shown in Table E.2 can be distinguished.

Table E.2 – List of cases, type T₁I

Type	Figure number	Source	Application
T ₁ I-a	Figure E.1	DC For example: PV	DC
T ₁ I-b	Figure E.2	AC For example: wind-turbine	AC
T ₁ I-c	Figure E.3	DC For example: PV	AC (conversion)
T ₁ I-d	Figure E.4	AC For example: wind-turbine	DC (conversion)

³ "in sync": when REN sources are available.

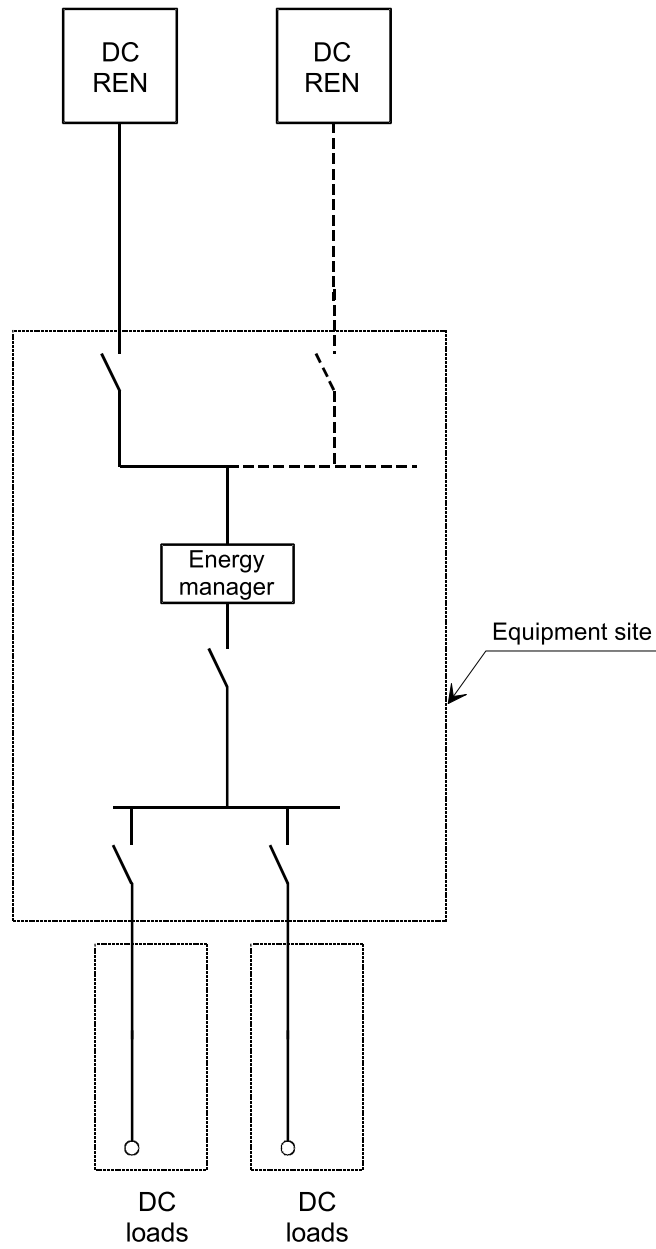

IEC

Figure E.1 – Type T₁I-a system

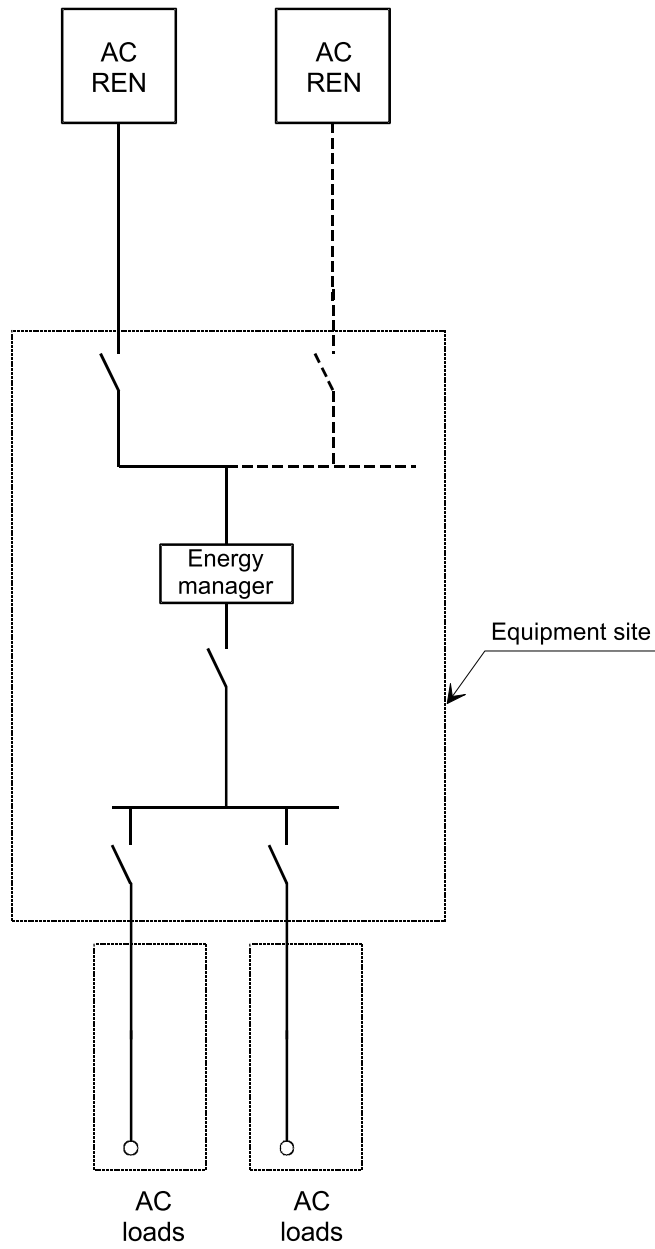

IEC

Figure E.2 – Type T₁I-b system

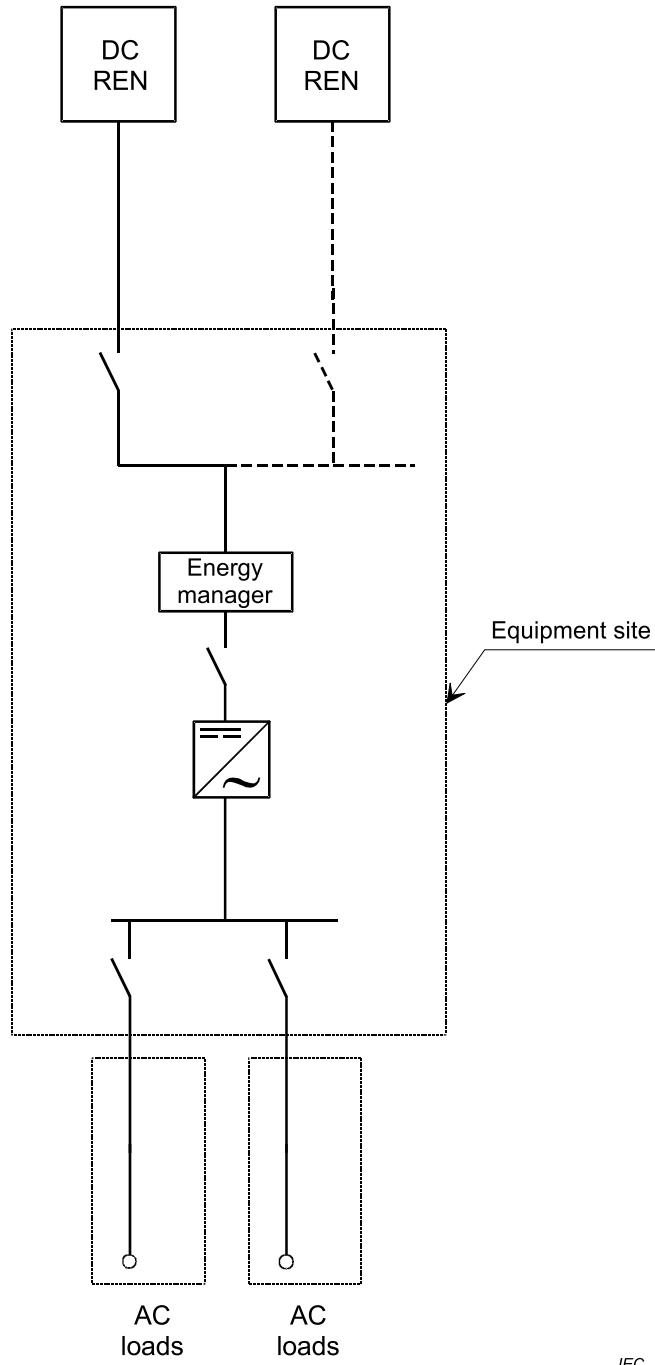

IEC

Figure E.3 – Type T_{1I}-c system

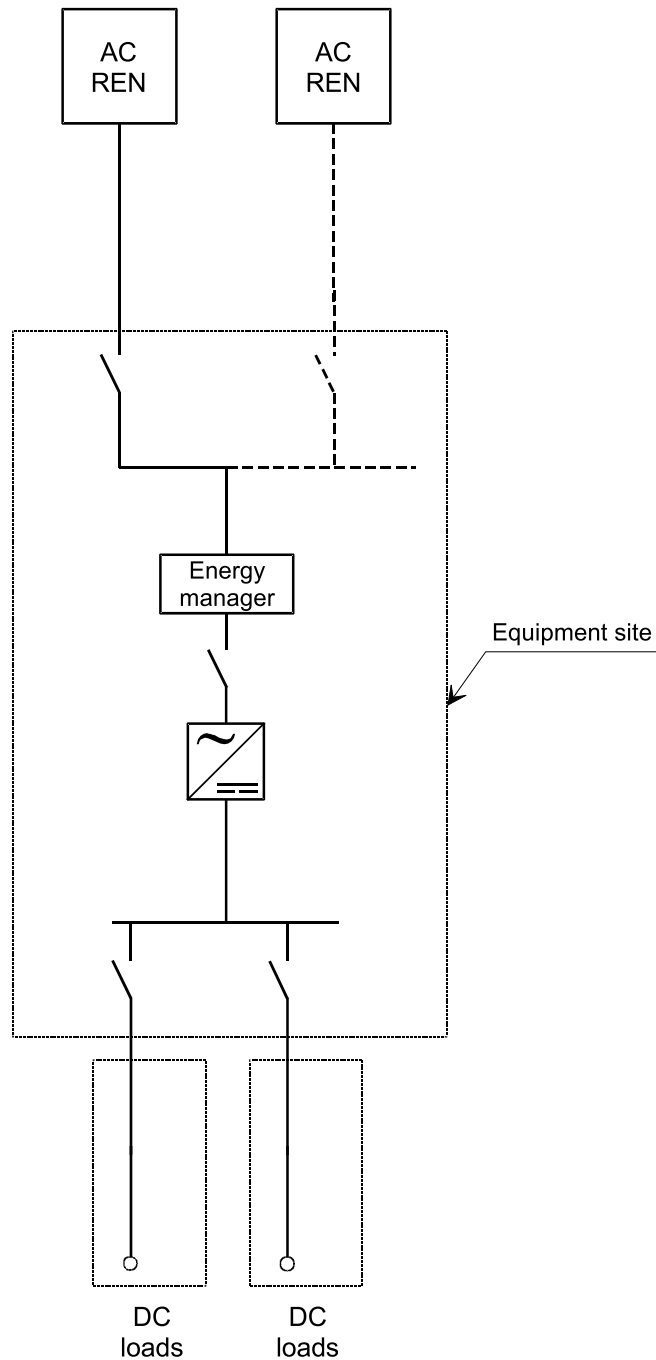

IEC

Figure E.4 – Type T_{1I-d} system

E.2.2 Type T_{2I}: Individual electrification systems – REN production with energy storage

This type of system, illustrated by Figure E.5, is primarily intended for users who specify having electric power when the sun is not shining or the not wind blowing. Accordingly, the system should have a capability of storing energy. However, the user does not specify a back up supply and accepts that limited storage will mean that some times will occur when the supply fails).

The demand appliances shall have equipment adapted to the appropriate voltage (for example DC voltage of 24 V or AC voltage of 230 V). Where necessary, the system should take into

consideration the constraints specific to direct current: power sockets, protection devices, earthing, etc.

The demand appliances may operate:

- on DC only;
- on AC only;
- dual DC/AC.

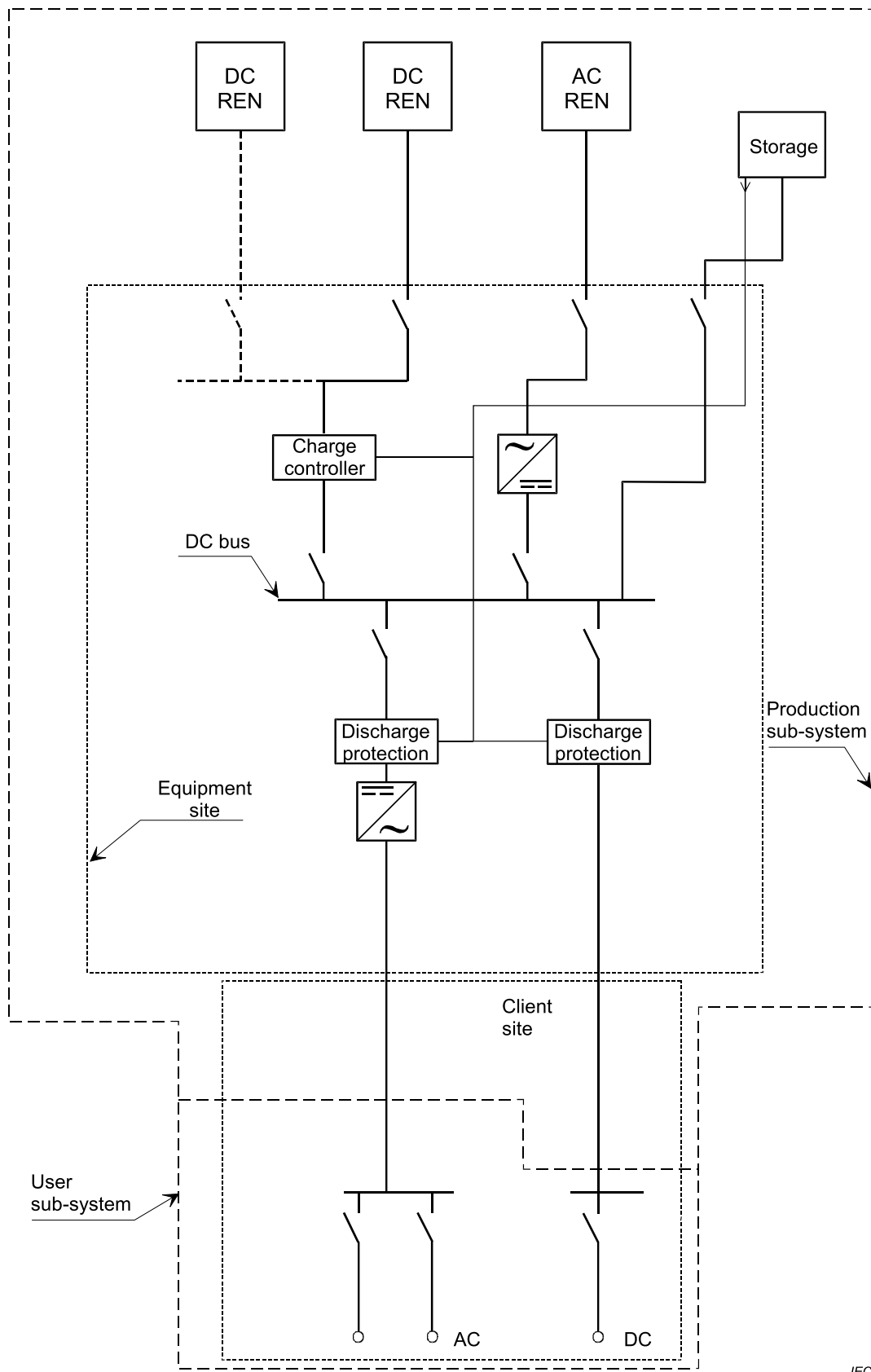

IEC

Figure E.5 – Type T₂I system

E.2.3 Type T₃l: Individual electrification systems: (REN + diesel) production without energy storage**Table E.3 – List of cases, type T₃l**

Type	Figure number	Source	Application
T ₃ l-a	Figure E.6	DC For example: PV	DC
T ₃ l-b	Figure E.7	AC For example: wind-turbine	AC

In such systems, there is no energy storage, but a minimum storage equipment is required to ensure the voltage level.

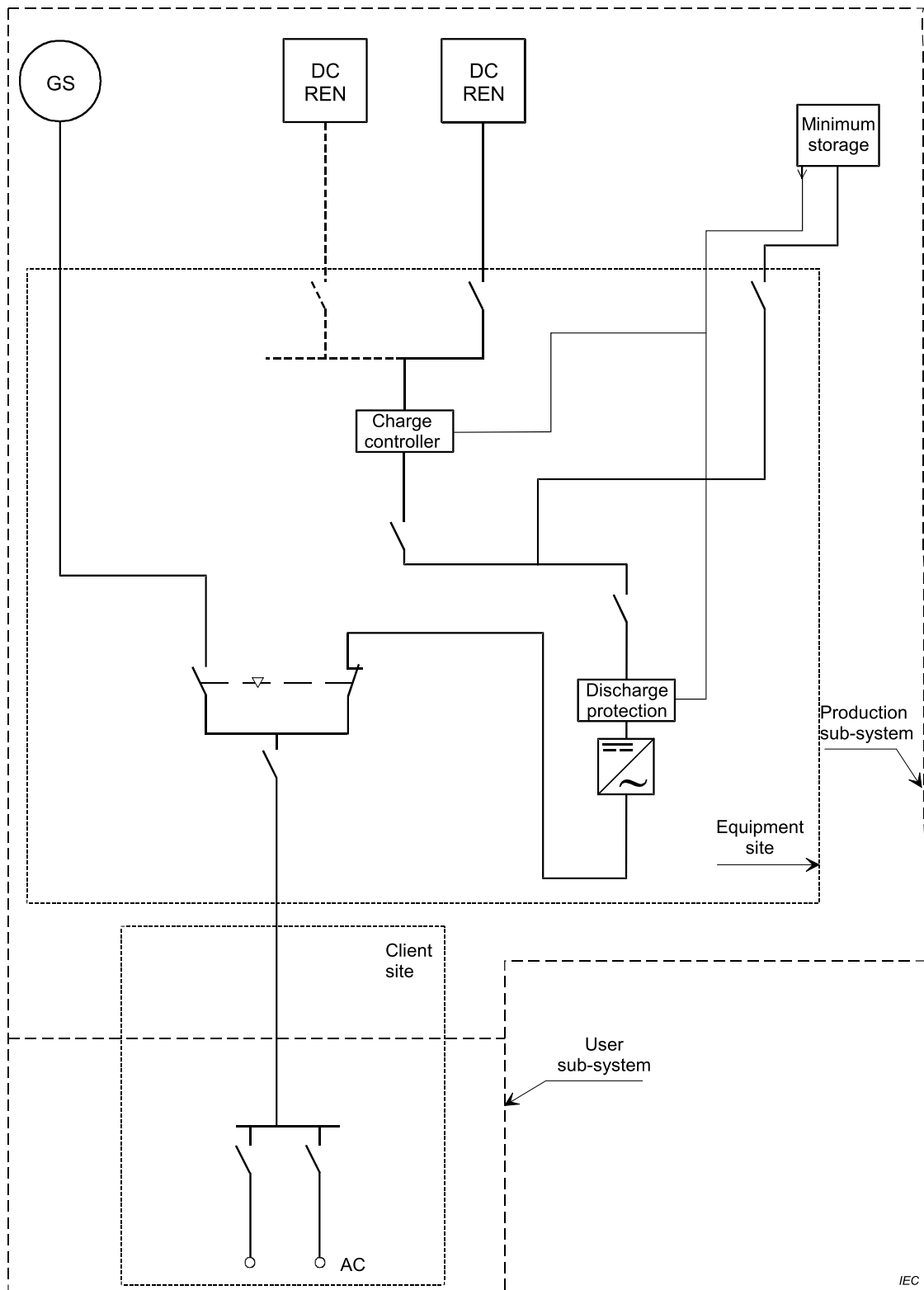

NOTE Minimum storage if applicable.

Figure E.6 – Type T₃I-a system

IEC

E.2.4 Type T₄I: Individual electrification systems: (RE + diesel) production with energy storage

This type of system, illustrated by Figure E.8 can meet energy requirements whether or not offset with relation to the production periods of renewable energy sources. The presence of a back-up set will provide the user with energy in unfavourable meteorological conditions without which storage would be unavailable or an over-dimensioned system would be required.

Two types of application can be supplied (DC and AC). Where both co-exist, two separate distribution circuits are required.

The AC application is normally supplied from storage batteries through an inverter. Typical reasons for starting the generator set would be:

- periodical recharging of the batteries (maintenance, equalising charge);
- imperative requirement to recharge batteries when the energy management system indicates “low battery”;
- the need to supply user equipment when the system is unavailable.

The availability of the generator set will then enable a dedicated application to be supplied from time to time when it is not possible or undesirable to do so from renewable energy sources.

The applications supplied may operate on:

- DC.
- AC. In this case, AC applications can be backed up by the set in the event of breakdown of the system. The applications cannot be supplied simultaneously by the generator set and the RE systems.
- both types (dual AC/DC supply). AC type applications can be backed up by the generator set under the same circumstances as above.
- both types, together with use of AC current dedicated to the generator set. In this case, in addition to backup identical to that of the two previous types, the generator set can supply a dedicated application. Where the application requires more power than the RE system is capable of providing, it will be supplied exclusively by the back-up generators or batteries.
- AC. In this case, AC applications can be backed up by the set in the event of breakdown of the system. The applications can be supplied simultaneously by the generator set and the RE systems.

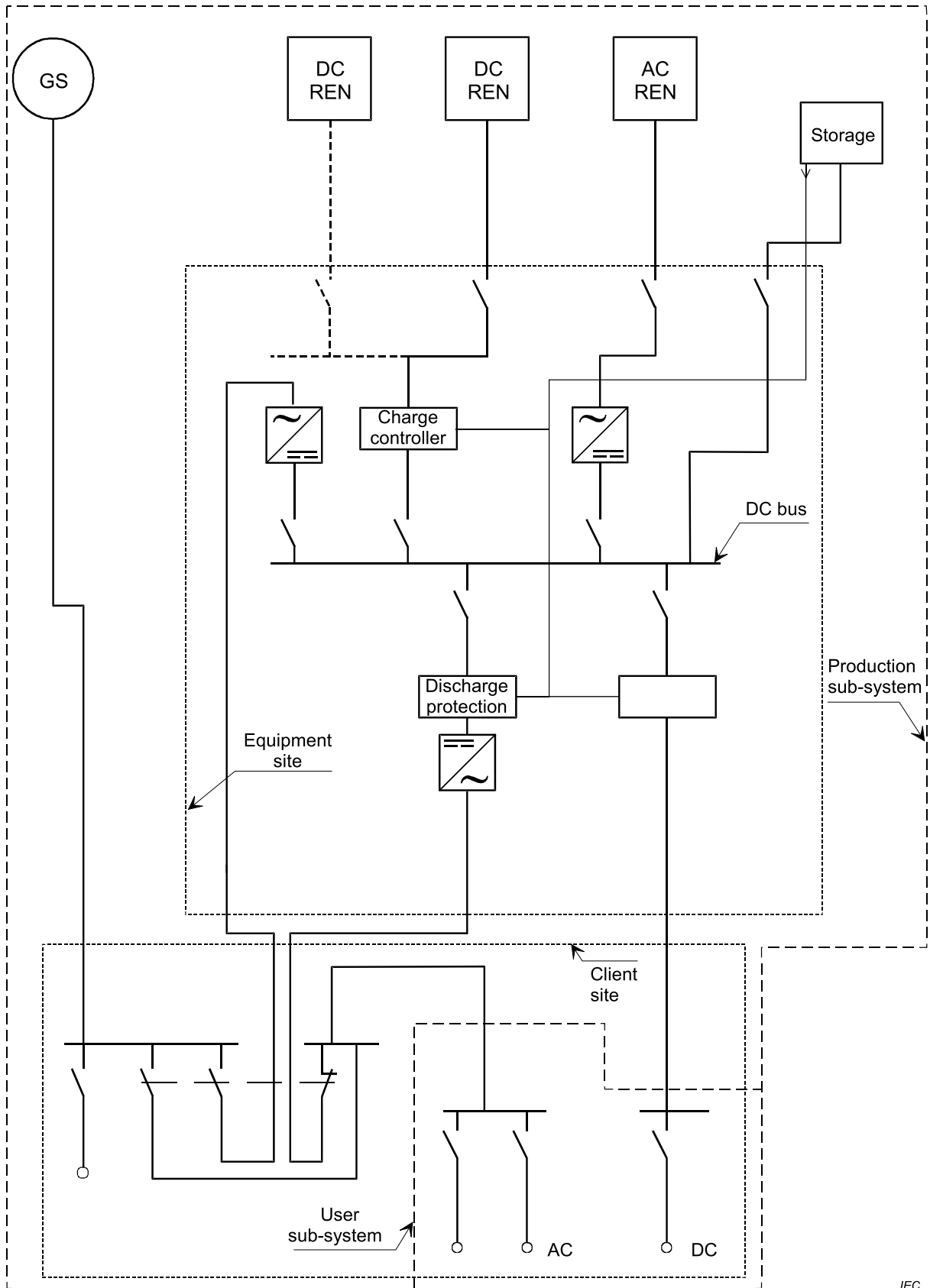

IEC

Figure E.8 – Type T_{4I} system

E.2.5 Type T₅I: Individual electrification systems: genset only without storage

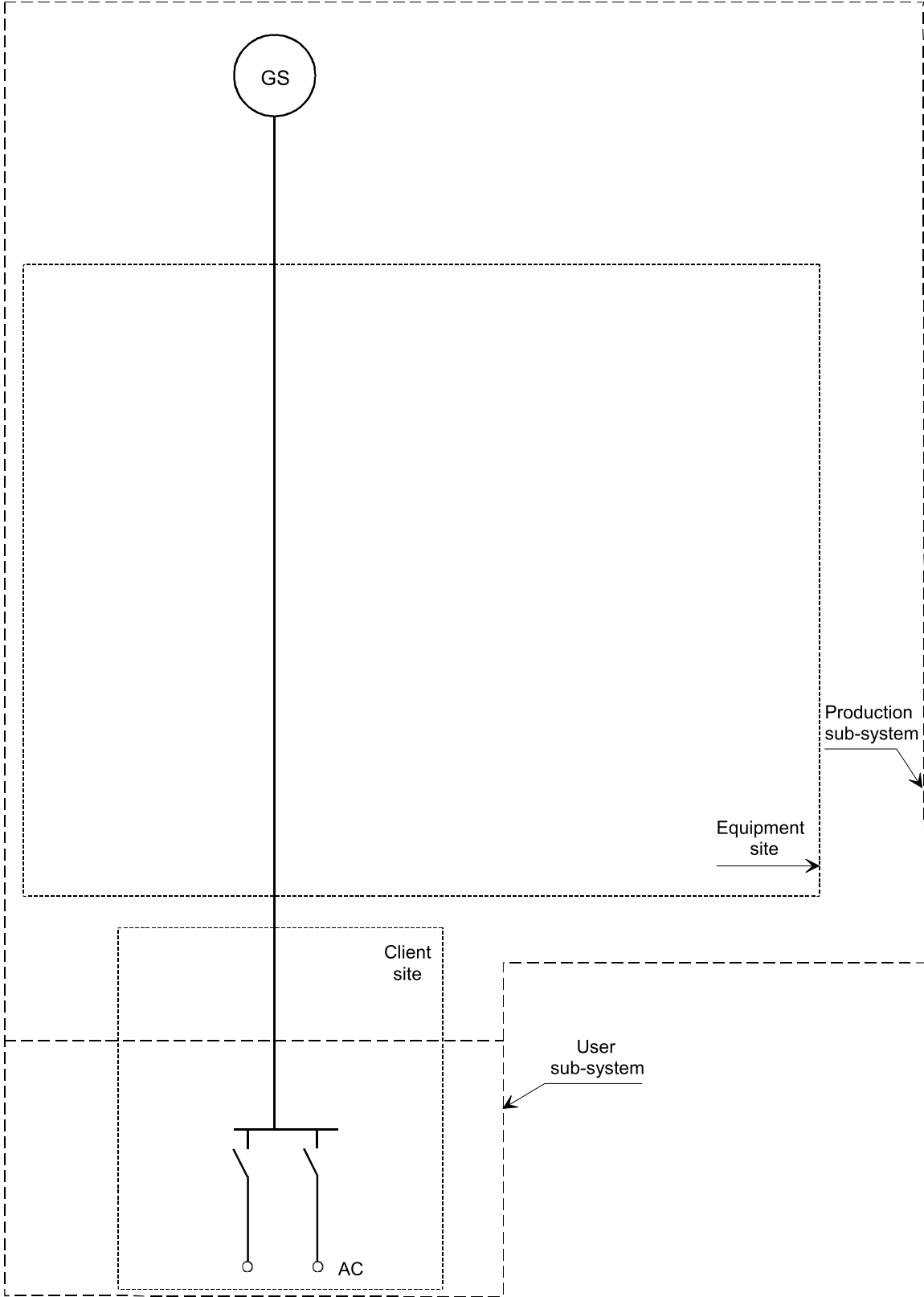

IEC

Figure E.9 – Type T₅I system

E.2.6 Type T₆I: Individual electrification systems: genset only with storage

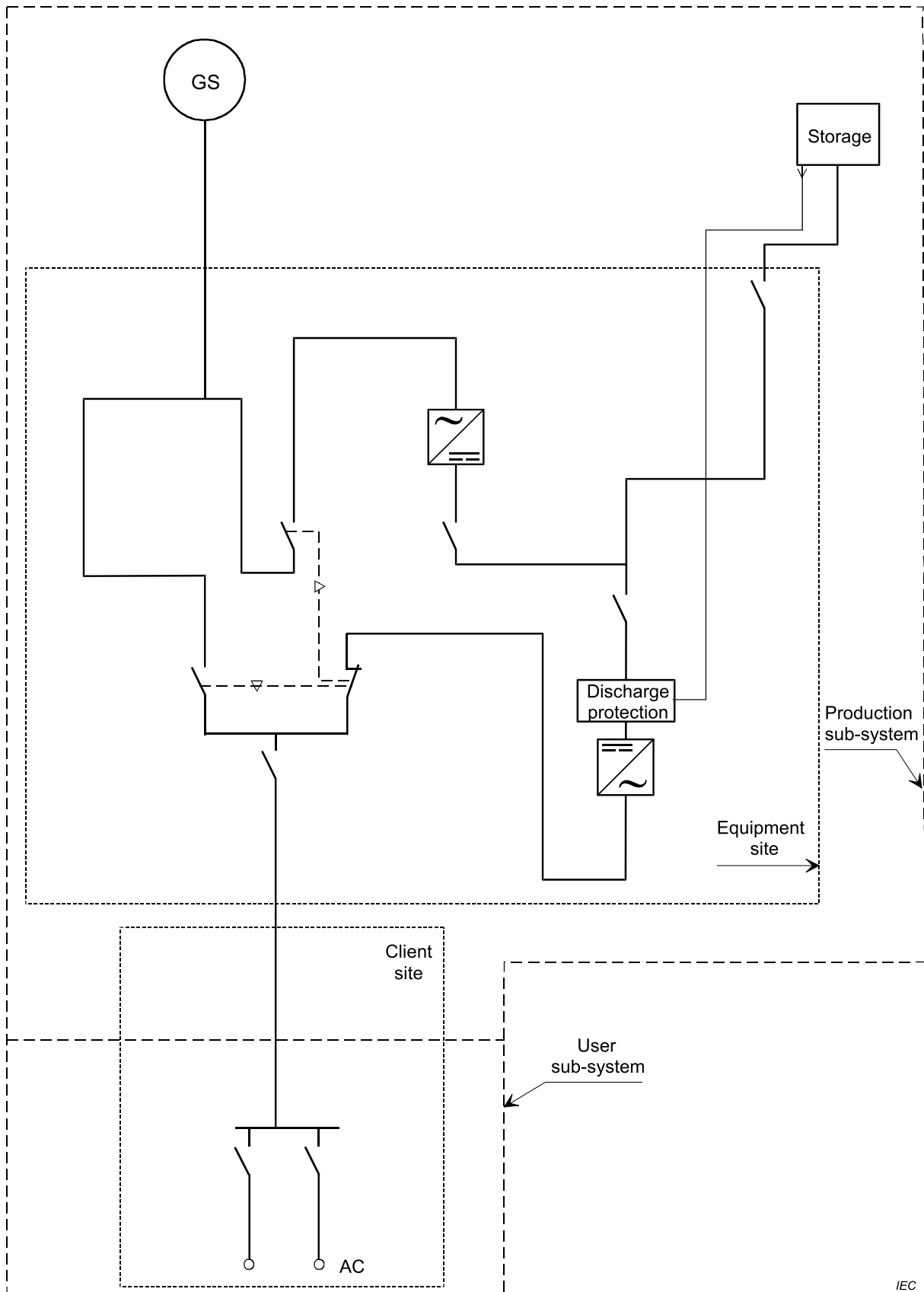

IEC

Figure E.10 – Type T₆I system

E.2.7 Type T₁C: Collective electrification systems: REN only without storage

Considered as non-relevant system.

E.2.8 Type T₂C: Collective electrification systems: REN Micropower plant supplying a microgrid

The type T₂C systems illustrated by Figure E.12 consists of REN micropower plants featuring energy storage supplying a microgrid to supply power to a few users or even a considerable number of users in concentrated rural dwellings (groups of houses, hamlets).

The production sub-system consists of generators (photovoltaic and/or wind-turbine), distribution boards providing network offtakes and converters for supplying energy at standard voltages (generally 230 V AC).

The distribution subsystem also comprises offtakes connected to the distribution boards of the production subsystem, the overhead lines or buried cables and the terminal delivery boxes at the user points. It is organised into a radial structure illustrated by Figure E.11.

The application subsystem starts from the terminals downstream from the user's delivery box and comprises the installations and equipment of the user, operating exclusively on AC.

The general architecture of the global system is illustrated by Figure E.11.

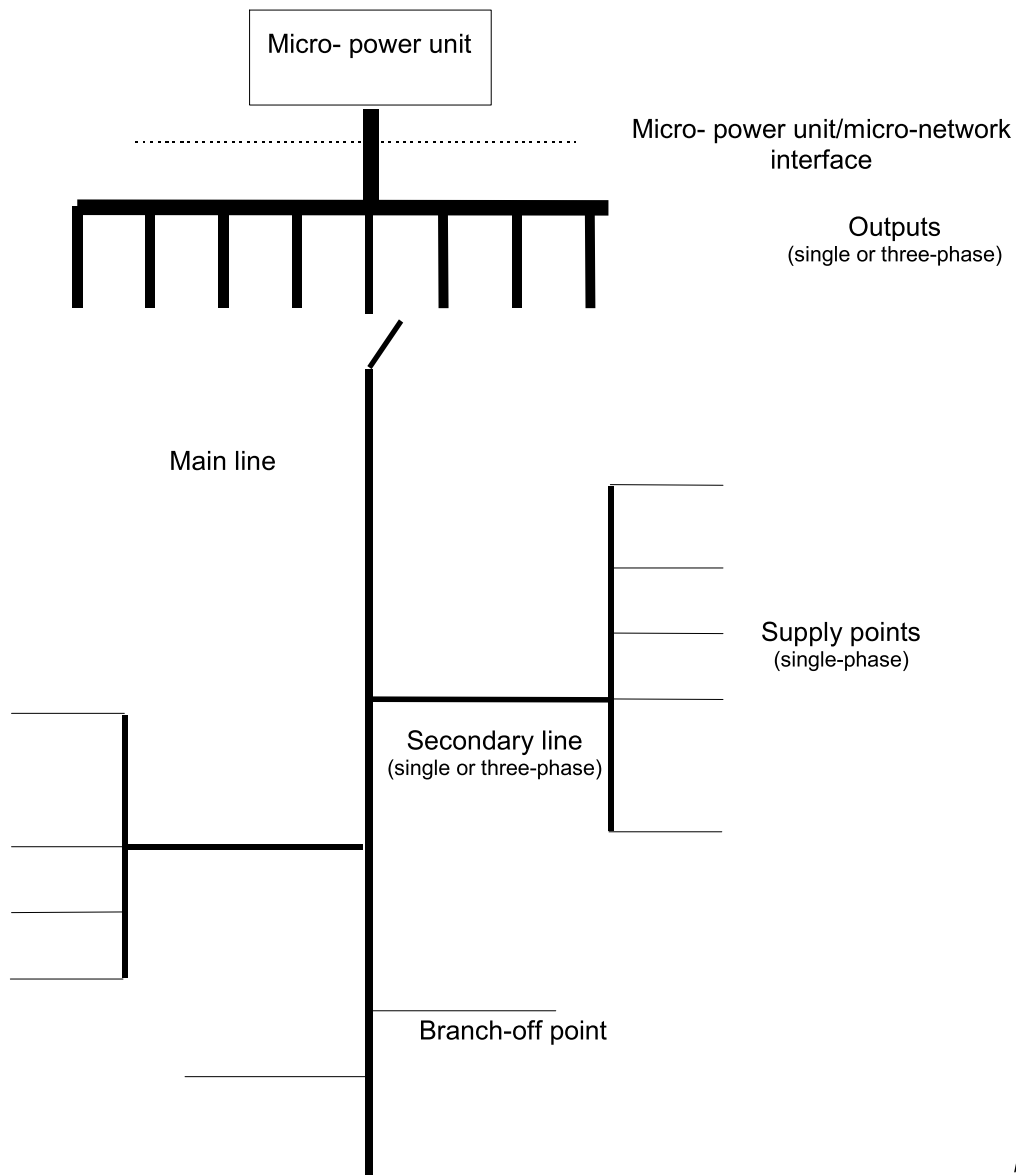
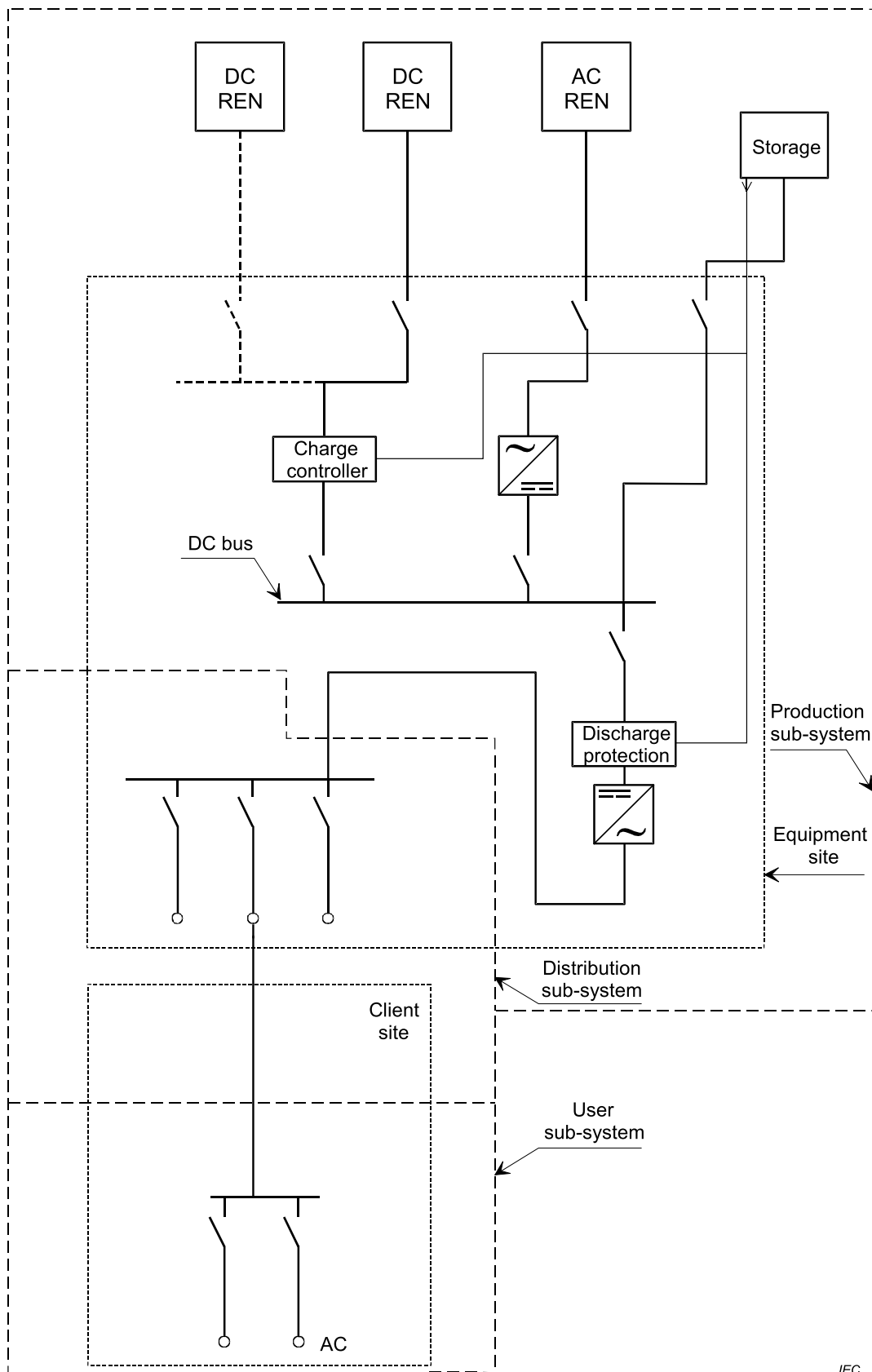

Figure E.11 – General architecture of a micropower plant supplying a microgrid



IEC

Figure E.12 – Type T₂C system

E.2.9 Type T₃C: Collective electrification systems: Multi sources micropower plant (RE + diesel) without energy storage, supplying a microgrid

Type T₃C systems, illustrated by Figure E.13 and Figure E.14 are diesel micropower plants with synchronous coupling to a system operating “in sync” with renewable energy sources. The production subsystem comprises a buffer battery the purpose of which is to set the input voltage of the inverter to facilitate coupling and enable the system to be supplied with power as the generator set runs up to operating speed.

These systems supply AC applications.

All AC sources being directly coupled shall be synchronised prior to connection.

Table E.4 – List of cases, type T₃C

Type	Figure number	RE source	Application
T ₃ C-a	Figure E.13	DC For example: PV	AC
T ₃ C-b	Figure E.14	AC For example: wind-turbine	AC

The distribution and application subsystems have the same structure as the type T₂C systems.

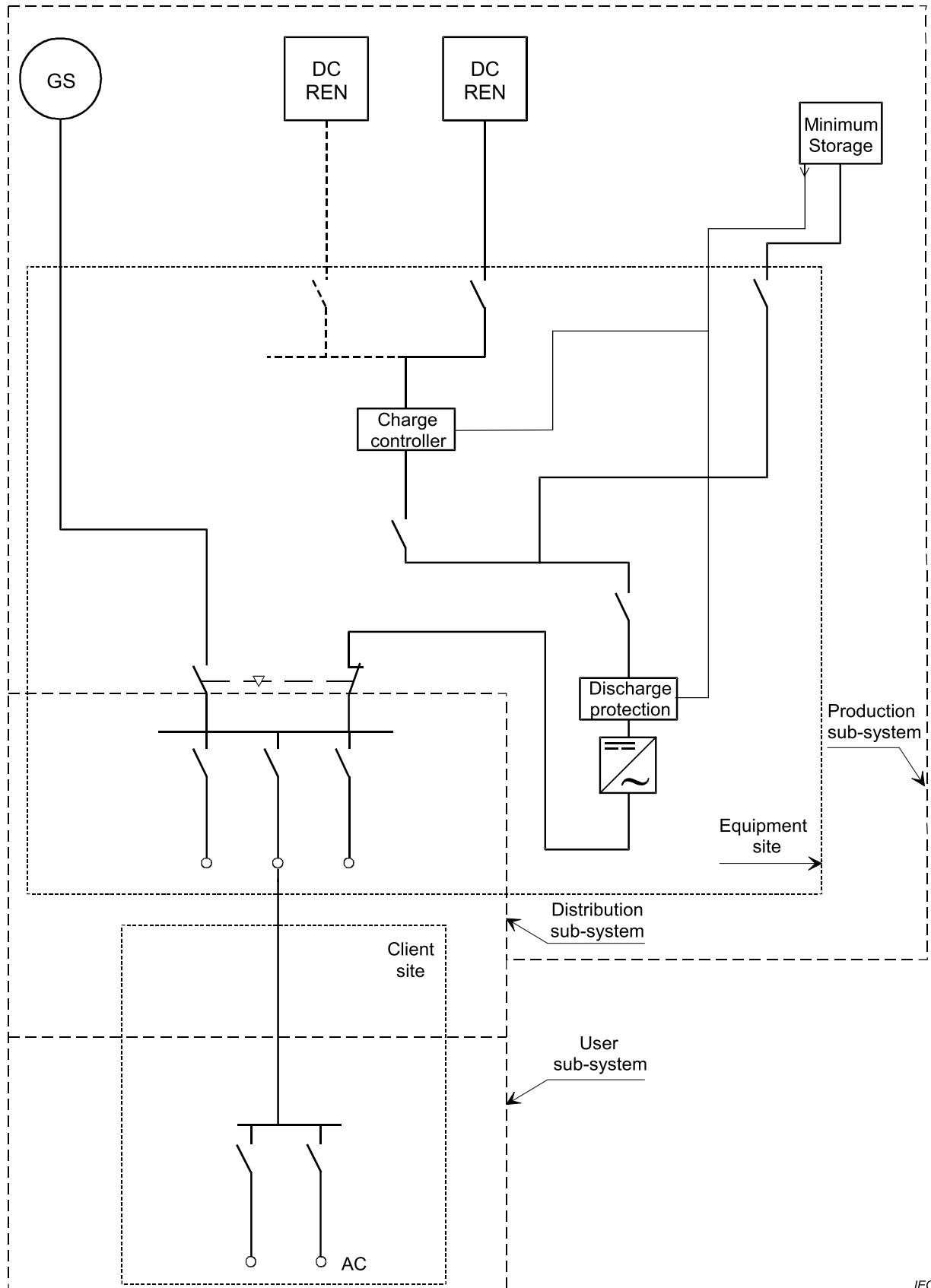

IEC

NOTE Minimum storage if applicable.

Figure E.13 – Type T₃C-a system

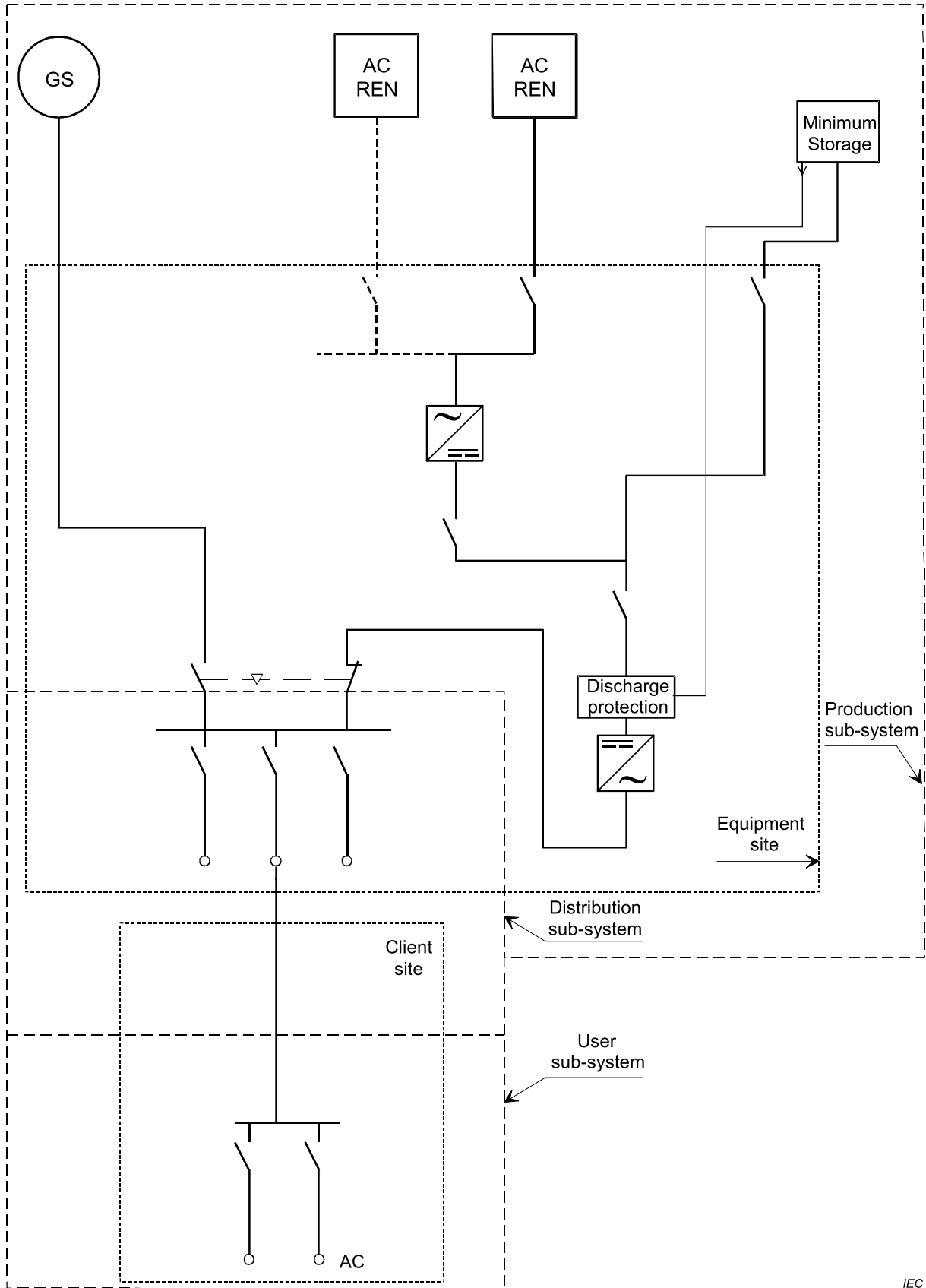

IEC

NOTE Minimum storage if applicable.

Figure E.14 – Type T₃C-b system

E.2.10 Type T₄C: Collective electrification systems: Multi sources micropower plant (RE + diesel) with energy storage supplying a microgrid

Type T₄C systems, illustrated by Figure E.15 and Figure E.16, consists of hybrid micropower plants (RE + diesel) with energy storage supplying a microgrid the purpose of which is to provide energy to a few users or a large number of users concentrated into nearby (rural) dwellings. These systems comprise a back-up source the minimum function of which is periodically to provide an equalisation charge for the batteries.

The availability of a back-up generator also makes it possible to secure the supply for users that it is critical to have a continuous supply (for example the medical dispensary and vaccine refrigerator, the school, economic and craft activities, community applications such as drinking water or irrigation). The number of users backed up will affect the dimensions of the make-up source and will partly determine the service level rendered by the micropower plant.

Activities that will never be connected to a backup generator would for example be domestic applications. The distribution between backed up activities and non-backed activities may vary with the needs and in certain cases tend to back up a maximum number of applications or on the contrary none at all.

The distribution and application subsystems have the same structure as the type T₂ systems.

Table E.5 – List of cases, type T₄C

Type	Figure number	Bus	Application
T ₄ C-a	Figure E.15	DC	AC
T ₄ C-b	Figure E.16	AC	AC

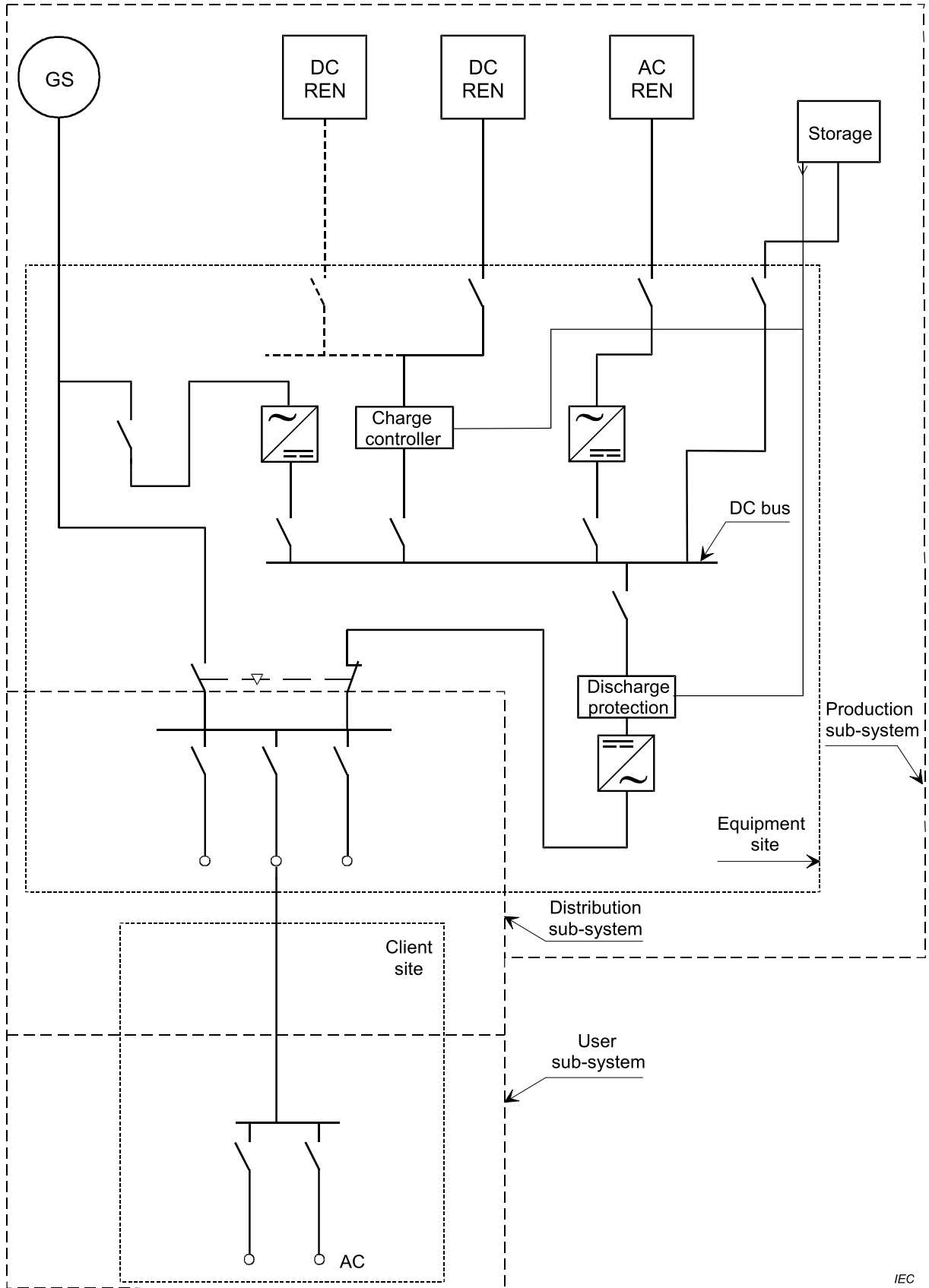
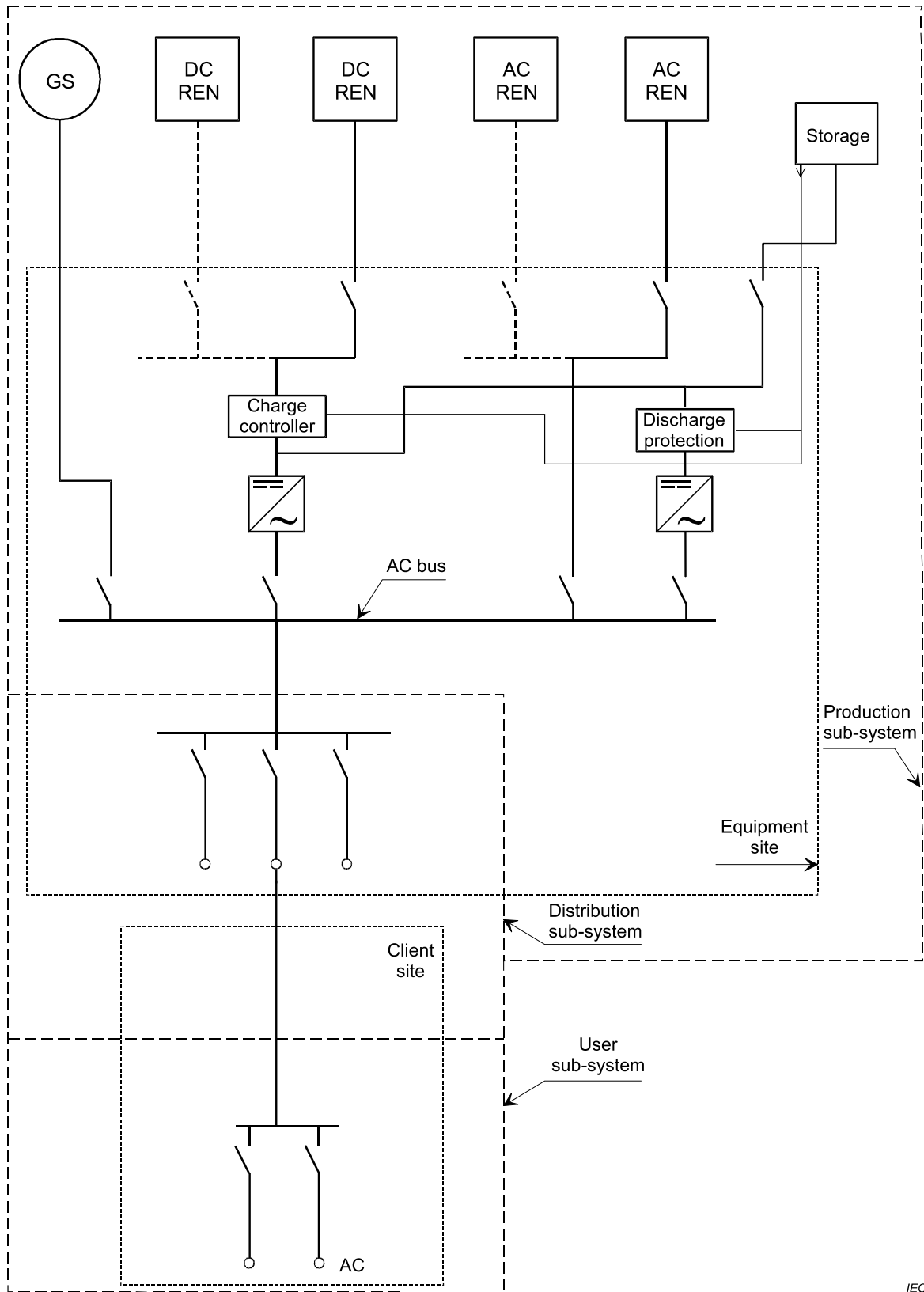

Figure E.15 – Type T₄C-a system

IEC



IEC

Figure E.16 – Type T₄C-b system

E.2.11 Type T₅C: Collective electrification systems: Diesel micropower plant supplying a microgrid

Type T₅C systems, illustrated by Figure E.17, are diesel micro-power plants diesel supplying a microgrid. The only energy source is a generator set directly supplying the network. In general, the set runs during pre-set time slots.

The distribution and application subsystems have the same structure as the type T₄ systems.

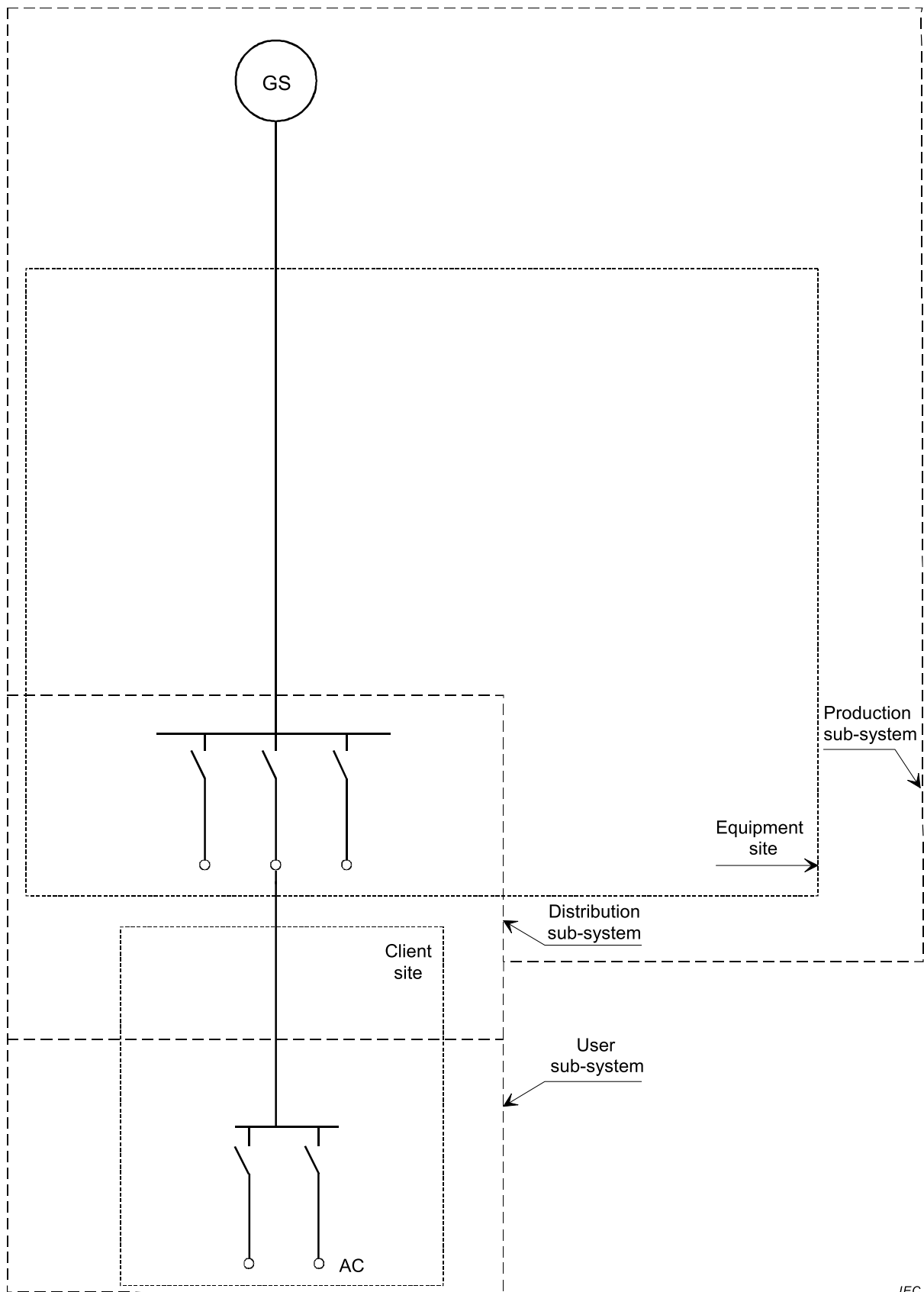

IEC

Figure E.17 – Type T₅C system

E.2.12 Type T₆C: Collective electrification systems: Diesel micropower plant with energy storage supplying a microgrid

Type T₆C systems, illustrated by Figure E.18, consist of diesel micropower plants with energy storage supplying a microgrid. The only energy source is a generator set directly supplying the network whilst simultaneously charging a battery. In general, the generator set runs during pre-arranged time slots. The battery renders the system independent outside the periods during which the generator set is running.

The distribution and application subsystems have the same structure as the type T₂C systems.

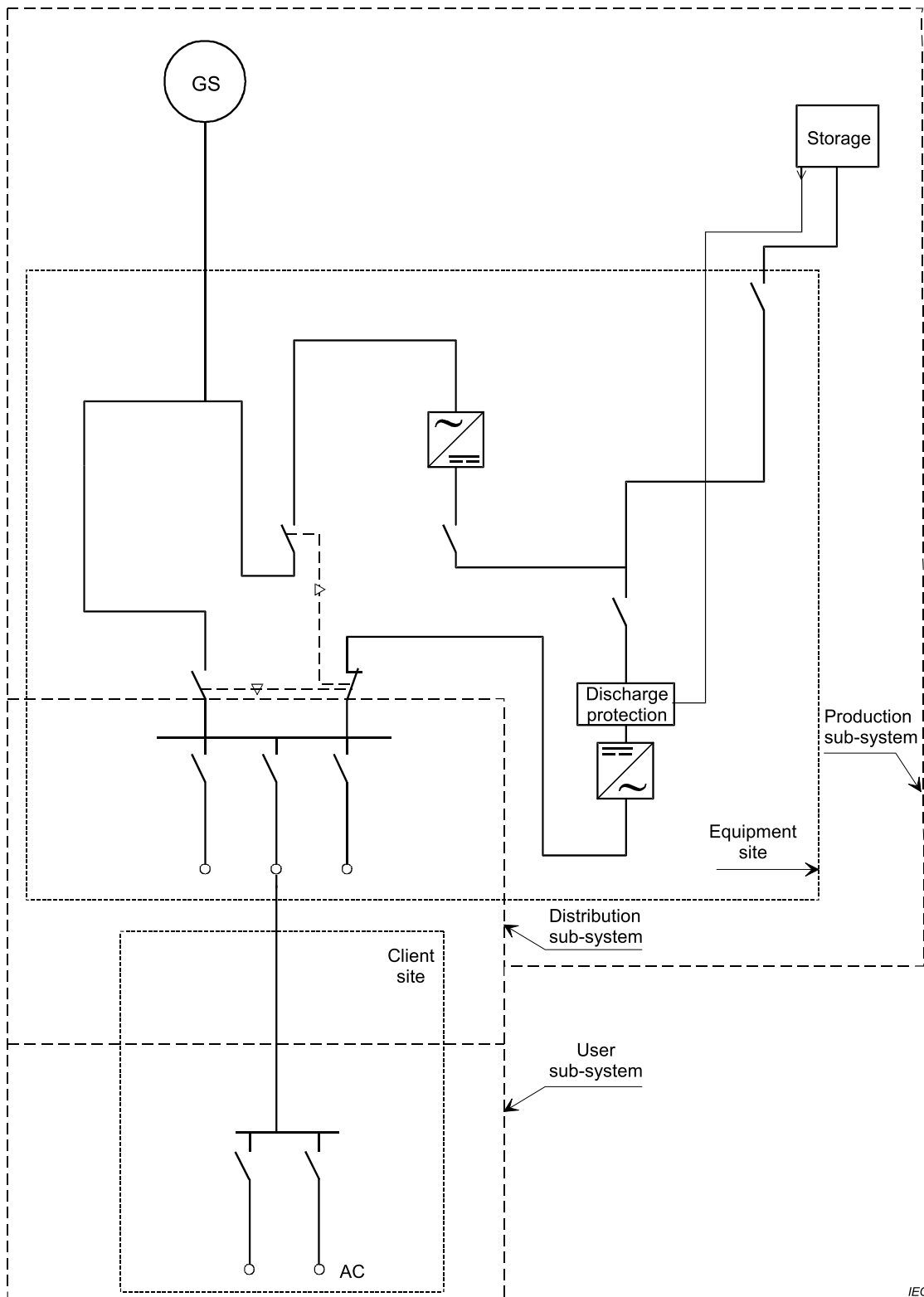

IEC

Figure E.18 – Type T₆C system

INTERNATIONAL
ELECTROTECHNICAL
COMMISSION

3, rue de Varembé
PO Box 131
CH-1211 Geneva 20
Switzerland

Tel: + 41 22 919 02 11
Fax: + 41 22 919 03 00
info@iec.ch
www.iec.ch